

TW7-6B

INSTRUCTION BOOK // PARTS CATALOGUE



EXTRA HEAVY-DUTY ZIG ZAG LOCKSTITCH SEWING MACHINE
EXTRA SCHWERE ZICK-ZACK-DOPPELSTIPPSTICH-NÄHMASCHINE

TYPICAL

- Please don't adjust and repair the machine by non-professionals, except adjusting stitch.
- Specifications subject to change without notice

TYPICAL SEWING MACHINE WANPING MACHINERY CO.,LTD.

ADD: WANPING TOWN, WUJIANG CITY, JIANGSU
PROVINCE, CHINA

TEL: +86-512-63391278

FAX: +86-512-63391371

POST. CODE: 215223

[Http://www.typicalwpchina.com](http://www.typicalwpchina.com)

E-mail: export@typicalwpchina.com

Printed in June. 2007

CONTENTS

Operation Instruction

1. Brief instruction.....	1
2. Main specifications.....	1
3. Preparation.....	1
4. Installing the motor.....	1
5. Connecting the pedal with clutch lever.....	1
6. Installing the presser foot lift control plate.....	2
7. Installing the belt guard.....	2
8. Installing the bobbin winder.....	2
9. Lubrication.....	3
10. Trial running.....	3
11. Installing the needle.....	3
12. Coordination among the needle, thread and material.....	4
13. Threading the needle thread.....	4
14. Winding the bobbin thread and adjustment.....	4
15. Stitch length, forward and backward feed.....	5
16. Oiling the thread take-up lever.....	5
17. Adjusting the pressure of presser foot.....	5
18. Installing the bobbin.....	6
19. Adjusting the thread take-up spring.....	6
20. Adjusting the tension of bobbin thread and needle thread.....	6
21. Installing the hook retainer bracket.....	7
22. Installing the feed dog.....	7
23. Adjusting the zigzag width.....	7
24. Adjusting the timing of feed.....	8
25. Regular cleaning.....	8

Parts Manual

1. Machine casting components.....	9-10
2. Upper shaft mechanism.....	11-12
3. Vertical shaft and hook mechanism.....	13-14
4. Needle bar rocking frame and presser bar mechanism.....	15-16
5. Needle plate and bottom feed mechanism.....	17-18
6. Thread tension and presser foot lifting mechanism.....	19-20
7. Reverse feed mechanism.....	21-22
8. Feed clutch mechanism.....	23-24
9. Puller mechanism.....	25-26
10. Zigzag gear and upper cover mechanism(-6BR).....	27-30
10. Zigzag gear and upper cover mechanism(-6BR-3/-6BR-4).....	27-30
11. Accessories.....	31-32

1. Brief introduction

This series large hook extra heavy duty zigzag sewing machines adopt link type thread take-up lever and driven by bevel gear, and large rotary hook. With the features of wide zigzag width and feed puller, they can stitch 4-point-3step or 3-point-2step or 2-point-1-step just through changing some parts.

This series machines are suitable for sewing leather, canvas, vinyl, etc, and also for stitching fishing net, and carpet edges.

3. Operation preparation

1. Clearing the machine

Before the head is packed, all of the parts of the machine are coated with anti-rust grease, meanwhile the grease can harden and the dust can cover the machine surface during long time storage and shipment, so, the dust and grease must be cleared by clean cloth with gasoline.

2. Examination

Although every machine is conformed by strict inspection and test before delivery, the parts of the machine may be loose and deformed after long distance transportation with jolt. A thorough examination must be performed. Turn the balance wheel slightly by hand to check if there is running obstruction, parts collision, uneven resistance and abnormal noise. If any of these exist, adjustment must be made accordingly before running.

4. Installing the motor(Fig 1)

Align machine hand wheel belt groove (A) With motor pulley belt groove (B) by moving motor (C) leftward or rightward, Be sure that the belt is not touched with the table.

5. Connecting the pedal with clutch lever(Fig.2)

- The optimum tilt angle of pedal against floor is approx. $20^{\circ} \sim 30^{\circ}$.
- Adjust the clutch of motor so that the clutch lever (C) and draw bar (B) run in line.
- The machine hand wheel should rotate counter-clockwise for normal sewing when view from opposite side of balance wheel. The motor should rotate in the same direction. The rotation can be reversed by reversing the plug of motor (turn over 180°)
- Adjust the tension of V-belt (F) by moving the motor up and down. The proper tension of V-belt is a slack of 10-12mm when the belt is depressed by fore finger. Release the forefinger, the belt will resume.

2. Main specifications

Max. Sewing speed	1000s.p.m
Max. Stitch length	7.5mm
Needle bar stroke	33.2mm
Presser foot lift height	10mm by hand 14mm by pedal
Zigzag width	0~12.7mm
Needle	DDxH14 25#
Hook	Large hook
Lubrication	Oiled by hand
Motor power	550W
Working space	254x195mm

Remarks: -R: with feed puller

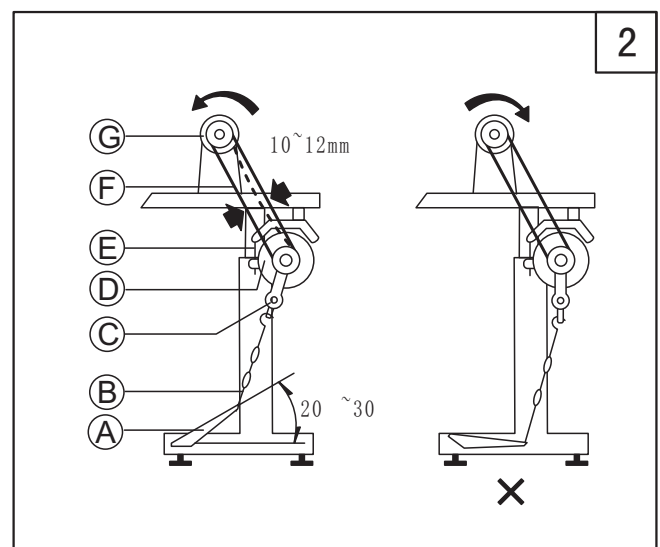
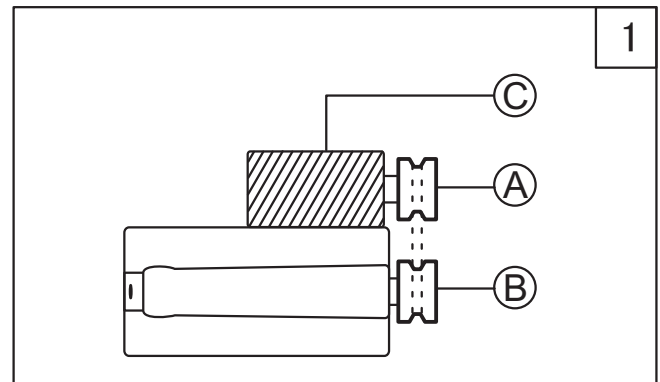

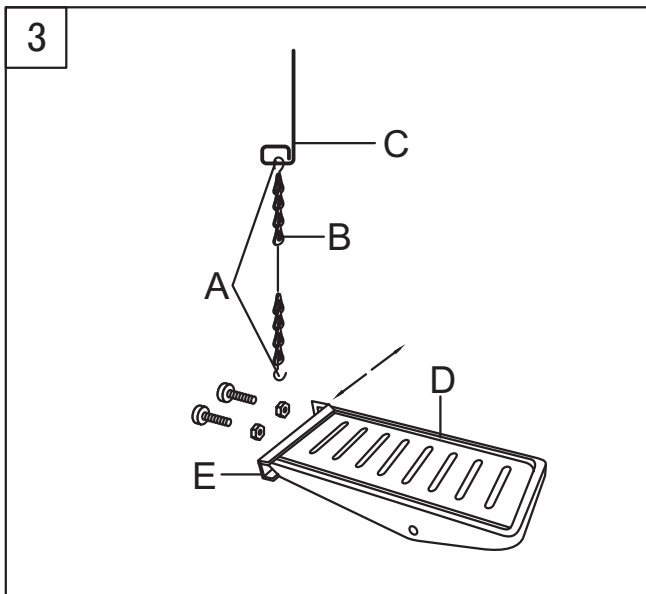

6. Installing the presser foot lift control plate(Fig.3)

Frist, the chain hook A should be connected with the chain B and presser foot lift lever C, then put the pedal assembly D on the stand, move the control plate E leftward or rightward until the chain becomes on one line, tighten the bolts and nuts, finally, connect the chain hook to the control plate.

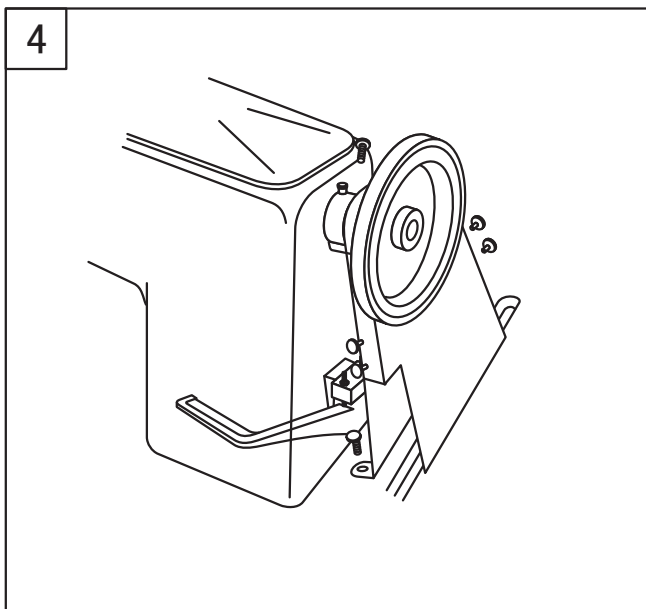

7. Installing the belt guard(Fig.4)

For the safety purpose, the belt guard should be installed as the Fig 4 shown.

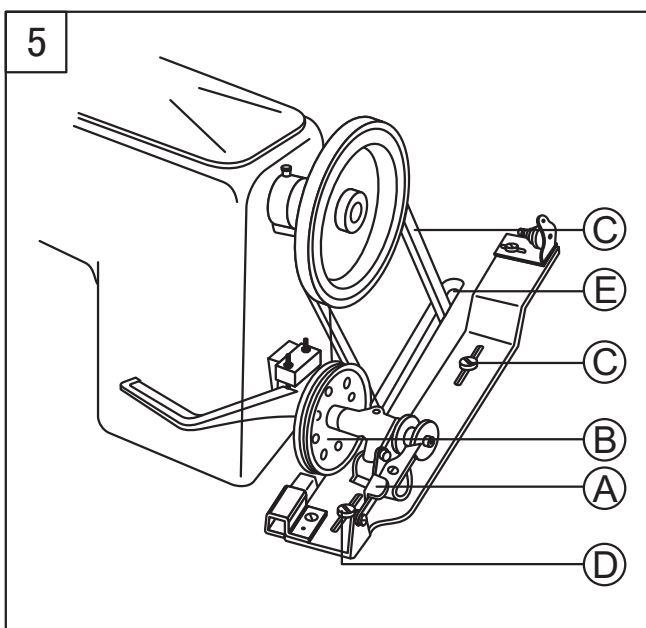

8. Installing the bobbin winder (Fig.5)

Align pulley B of the bobbin winder with the outside of the V-belt C, and there should be a proper clearance between them, so that pulley B can be touched with the V-belt when latch thumb lever A is depressed, thereby the V-belt can drive the pulley B while the machine running. The bobbin winder should be parallel with belt slit E of the table, finally fasten two wooden screws D.

9.Lubrication (Fig.6)

The machine must be oiled at the places with red mark after the work is over every day. After lubrication, please run 1 or 2 minutes.

10.Trial running

Trial running is required when new machine is put into use or use again after storing quite long time. First uninstall the rubber plug above the machine head and face plate and oiled by hand, then lift the presser foot and run the machine at a low speed of 300~400s.p.m for 30 minutes, then increase the speed gradually. After one month, please choose the suitable speed according to the sewing work.

11.Installing the needle (Fig.7)

Turn the balance wheel to lift the needle bar to its highest position, loosen the needle set screw, and make the needle groove to the left side of the operator, then fully insert the needle shank until the bottom of the needle bar socket, tighten the set screw.

Note: Insufficient insertion (Fig. b) or the needle groove facing to the operator (Fig.c) is incorrect.

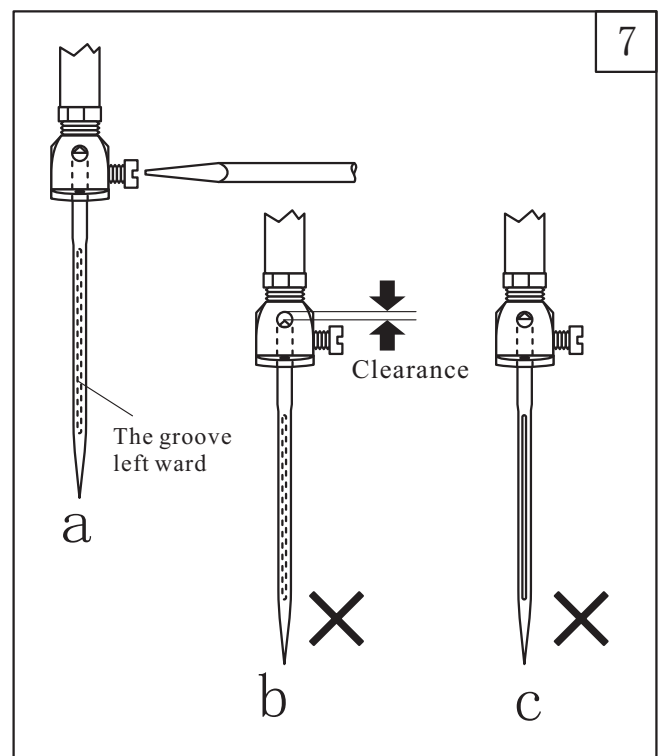
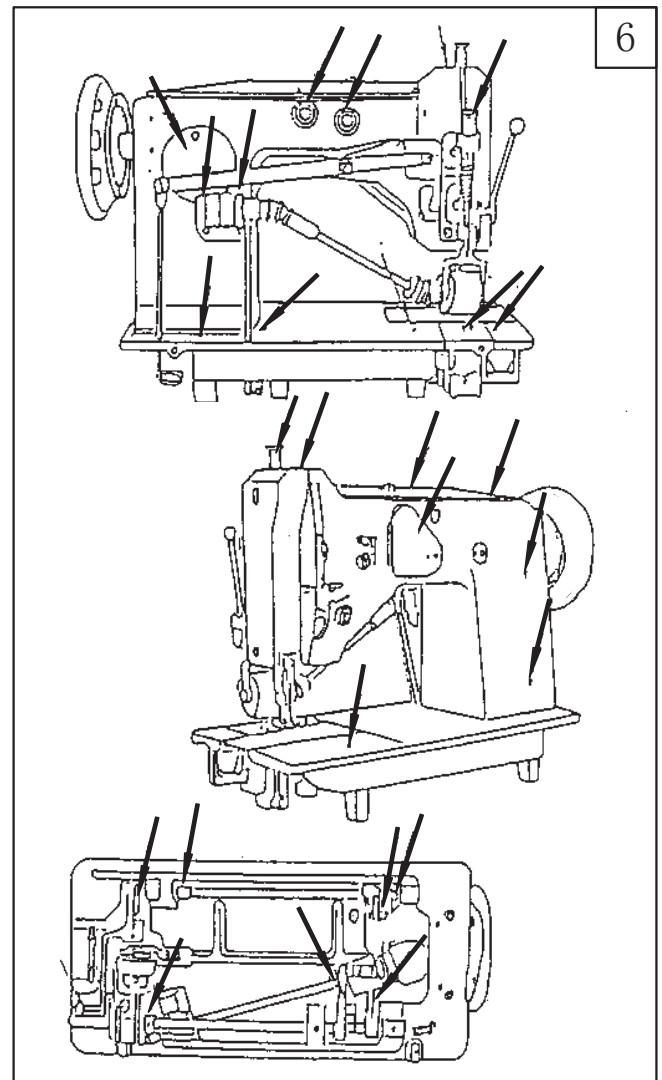

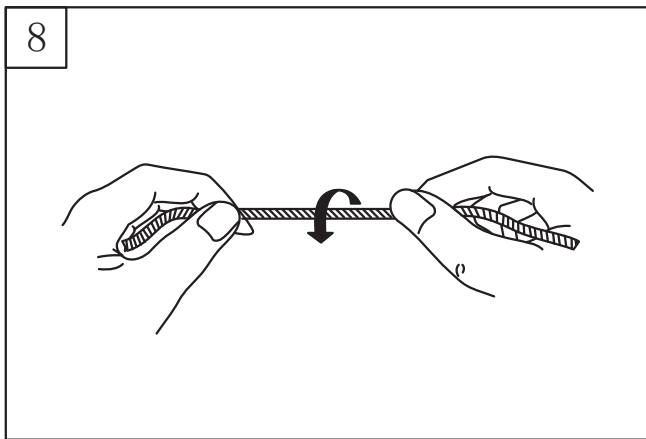

12.Coordination among the needle, thread and materials(Fig.8)

The needle thread should be left-twist, holding the thread by left hand, twist it by right hand at certain direction (shown as Fig.10), if it changes into tight, it's left-twist, contrary, it's right-twist. Please use needle DD x 1 22#~27#, the needle size should depend on the materials to be sewn. If the thin needle is used for sewing heavy materials, the needle will be broken easily, and will also cause skip and thread broken. On the contrary, the materials will be destroyed for the big needle hole, so please select proper needle and thread according to the materials.

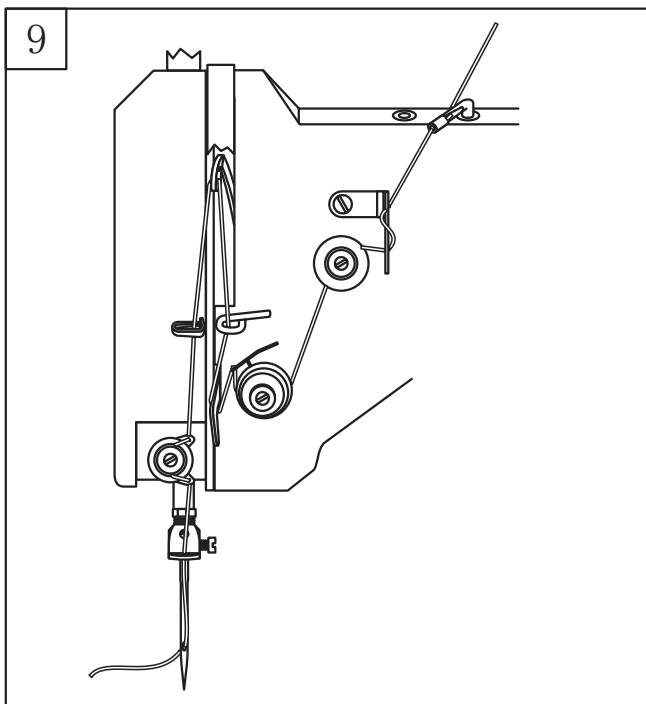

13.Threading the needle thread (Fig.9)

Turn the hand wheel to lift the needle bar to its highest position, then threading as following sequence shown in the Fig.9

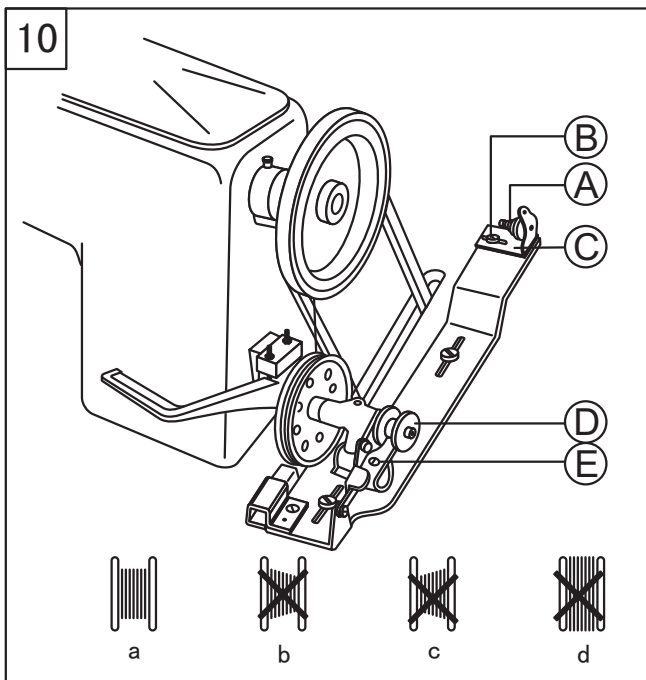

14.Winding the bobbin thread and adjustment (Fig.10)

Bobbin thread should be neat and tight. If loose, please increase the tension of tension disc A; if not neat, please move the winder bracket C to adjust, When adjust, first loose the screw B, then move the barcket C rightward if the thread is wound to one side as Fig(b) shown; or move the barcket C leftward if the thread is wound to one side as Fig(c) shown until the thread is wound neatly as Fig.(a) shown, finally fix the bracket.

Note: nylon or olyester thread should be wound under light tension in particular; otherwise bobbin D might be broken or deformed. Please don' t overfill the bobbin thread; otherwise the thread will loosen down from the bobbin. The optimum capacity of thread is filled about 80% of bobbin outside diameter and adjusted by screw E.

15. Stitch length, forward and backward feed (Fig.11)

The stitch length can be adjusted by the button A. Press the button, then turn the hand wheel B clockwise to decrease the stitch length or counter-clockwise to increase the stitch length. After adjustment, please test the stitch length by paper until the required length is reached. Finally, please check the error between forward and backward feed. If the backward feed is short, turn the screw C counter-clockwise, then tighten the nut; if the backward feed is long, turn the screw D to adjust.

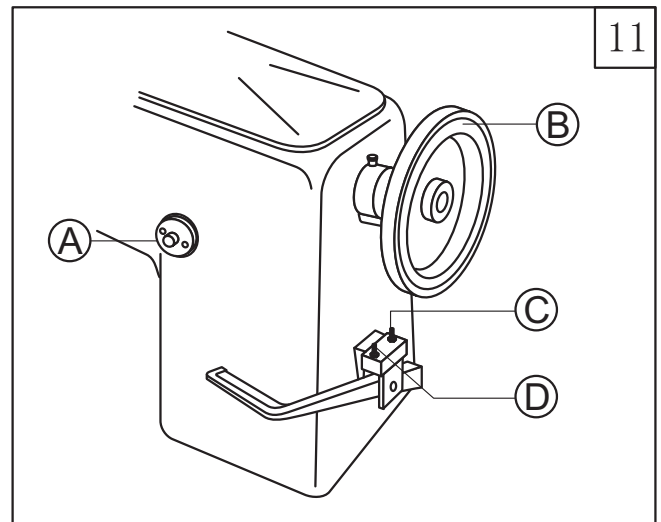

16. Oiling the thread take-up lever (Fig.12)

The thread take-up lever and needle bar is lubricated by oil woolen wick, if the oil wick has no the function because of the pollution or hardened, please change a new on:

1. Open the face plate, uninstall the screw, lock nut.
2. Pull out the pin A, and take out the oil wick.
3. Take out the oil wick in the B
4. Change a new one.
5. The installation steps are counter-sequence.

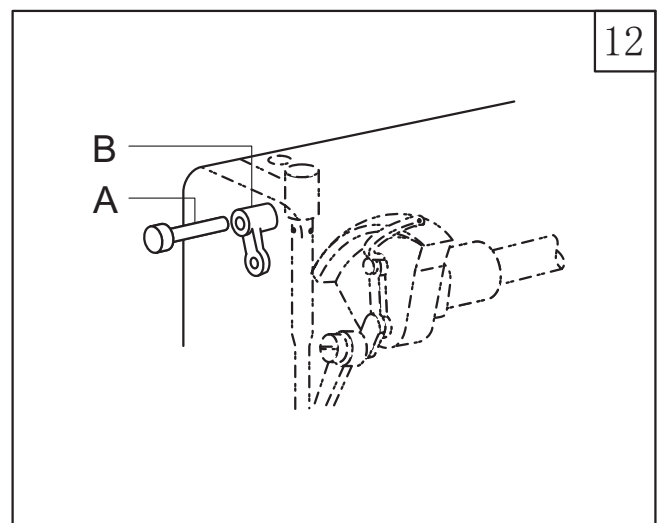

17. Adjusting the pressure of presser foot (Fig.13)

Adjust the pressure of presser foot according to the materials. First loosen the nut A, then turn the thumb screw clockwise (a) to increase the pressure, on the contrary, to decrease the pressure, after the proper pressure is obtained, tighten the nut A. The proper pressure is assure the materials be feed properly.

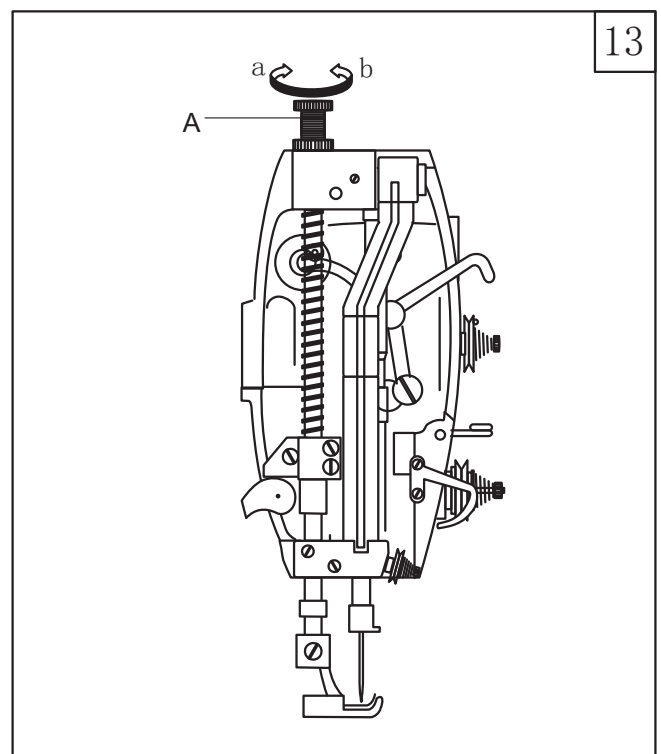

14

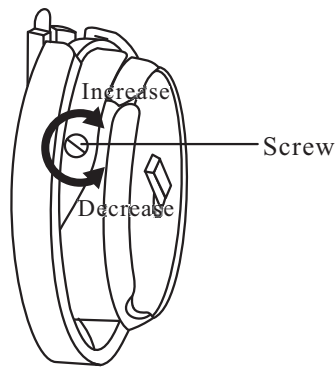

18.Installing the bobbin (Fig.14)

The thread tension should be adjusted according to the materials, thread and stitch seam.

The bobbin thread tension can be adjusted by the screw shown in the Fig.14

Based on it, the needle thread tension can be adjusted through the thread take-up spring, tension disc and the position of thread guide.

15

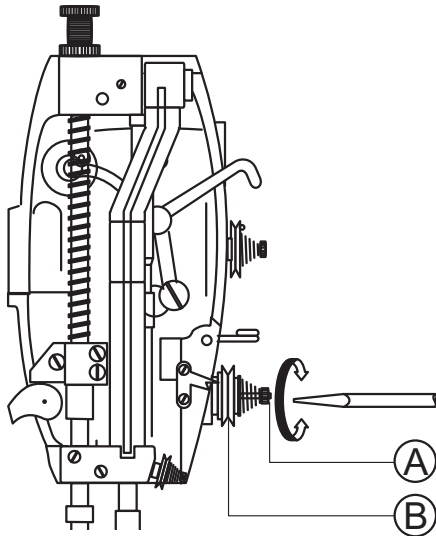

19.Adjusting the threrad take-up spring (Fig.15)

The swing range of the thread take-up spring should be 5~8mm. If stitch the light materials (stitch length is also short), the spring tension should be lower and increase the swing range, vice versa.

1. Adjust the tension of thread take-up spring

Turn the screw A clockwise to increase the tension, on the contrary, to decrease the tension.

2. Adjust the swing range of the spring

Loosen the screw A, turn the disc B clockwise to increase the swing range, on the contrary, to decrease the swing range.

Usually the tension and swing range have been set by the maker, only sewing the special materials or use special thread, it should be reset.

16

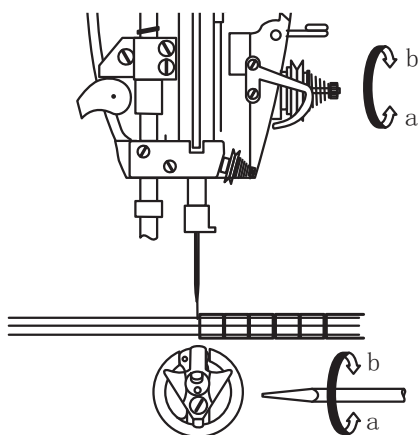
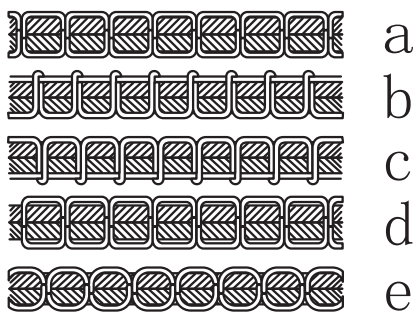

20.Adjusting the tension of bobbin thread and needle thread (Fig.16)

The normal stitch of sewing machine is shown in Fig.a. If stitch is abnormal, the puckering and thread breakage will occur, the needle thread tension and bobbin thread tension should be adjusted so that the normal stitch can be obtained.

a.If The stitch seam shows as Fig. B, indicates that the needle thread tension is too tight or the bobbin thread tension is too loose. Please turn the thread tension nut counter-clockwise to release the needle thread pressure; or turn the bobbin lace adjusting screw with a screwdriver to increase the bobbin thread tension.

B.If the needle thread tension is too loose or the bobbin thread tension is too tight shown as Fig.c Please turn the thread tension nut clockwise to increase the needle thread pressure; or turn the bobbin lace adjusting screw with a screwdriver to decrease the bobbin thread tension.

C.If the stitch seam shows as Fig,d,e. It also can be adjusted by referring to above methods.

21. Installing the hook retainer bracket(Fig.17)

While install the hook retainer bracket E, first tighten the screw D, adjust the clearance between bracket and hook to 1.2~1.5mm, and the clearance between the spring tip C and bobbin case to 1~1.2mm, which assure the C to keep the bobbin case. Please don't let the C be touched with the hook tip B, if so, please adjust the position of E again, finally tighten the screw D.

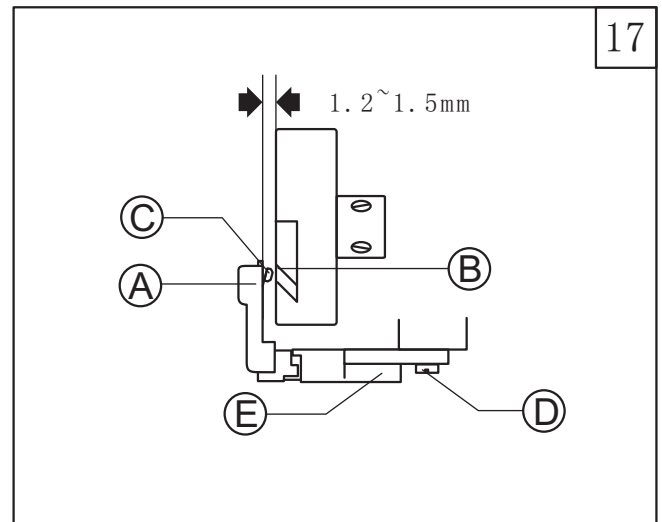

22. Installing the feed dog (Fig.18)

A. When the feed amount reaches maximum, the standard position of feed dog is the clearance between the feed dog and needle plate is 1.5mm

B. Adjustment: first move the feed dog forward to the needle plate as it can, then loosen the screw (A) (Fig.29b), move the feed bar (B) as shown by the arrow (Fig. 29a), after adjustment, tighten the screw (A).

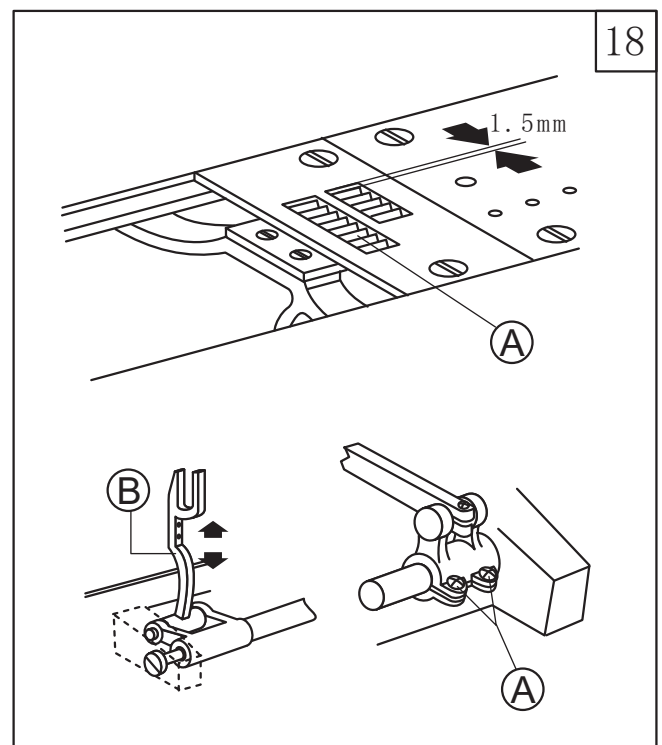

23. Adjusting the zigzag width (Fig.19)

Open the cover A, then loosen the screw C to make the lever B move upward to decrease the zigzag width or downward to increase zigzag width. The Zero means the straight stitch.

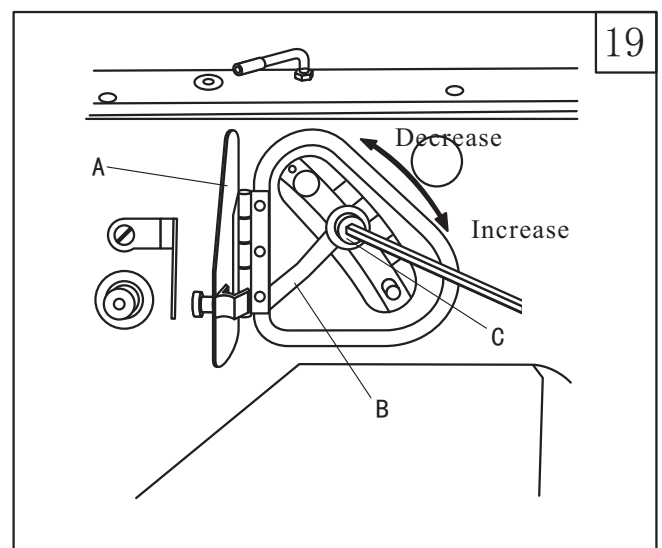

20

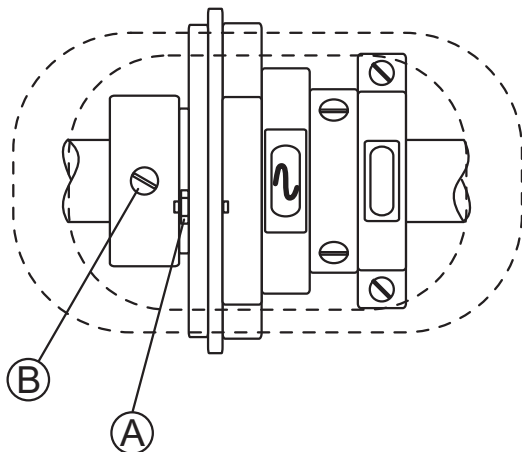
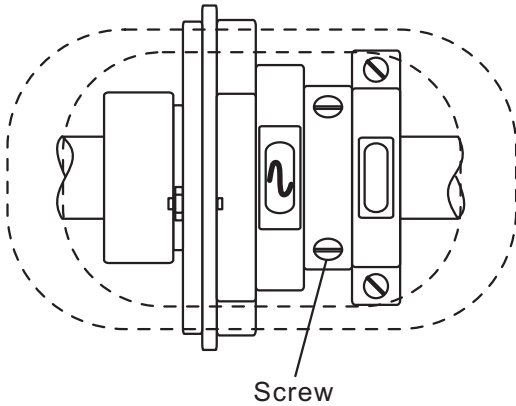
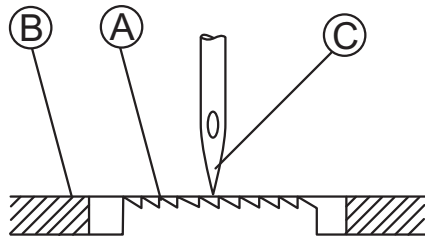

24.Adjusting the timing of feed(Fig.20)

1. Standard position

Turn the hand wheel to lower the feed dog (A) when the feed dog and the surface of needle plate(B) is at the same level, the tip of needle (C) and needle plate and feed dog should be at same level.

2. Installing the feed lifting cam

Open the upper cover, turn the hand wheel counter-clockwise by hand to lift the needle bar to the top position, the first screw on the cam should be tilted 45° counter-clockwise.

3. Installing the feed cam

After install the feed lifting cam, next install the feed cam. Lift the needle bar to the top position, look the feed lifting cam as the frame of reference, the screw (A) should be tilted 30° counter-clockwise, in other word, the tilted angle is 15° clockwise against the first screw of feed lifting cam. Then tighten the screw (B).

21

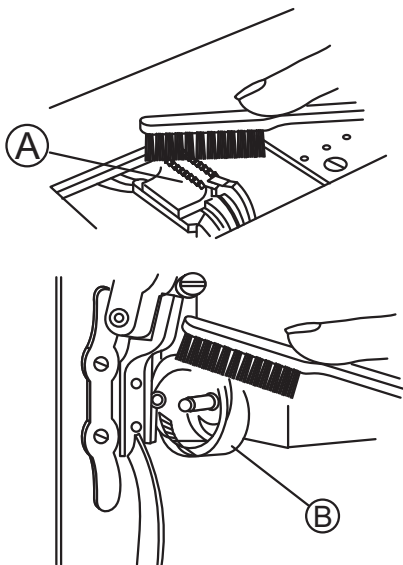

25.Regular cleaning(Fig.21)

Please clean the feed dog, hook and bobbin case regularly.

1. Cleaning the feed dog.

Uninstall the needle plate, clean the dust on the feed dog, after clean, install the needle plate.

2. Cleaning the hook

Clean the hook with a soft brush as shown in the Fig. 21. Meanwhile clean the bobbin case with a soft cloth.

1. Machine casting components

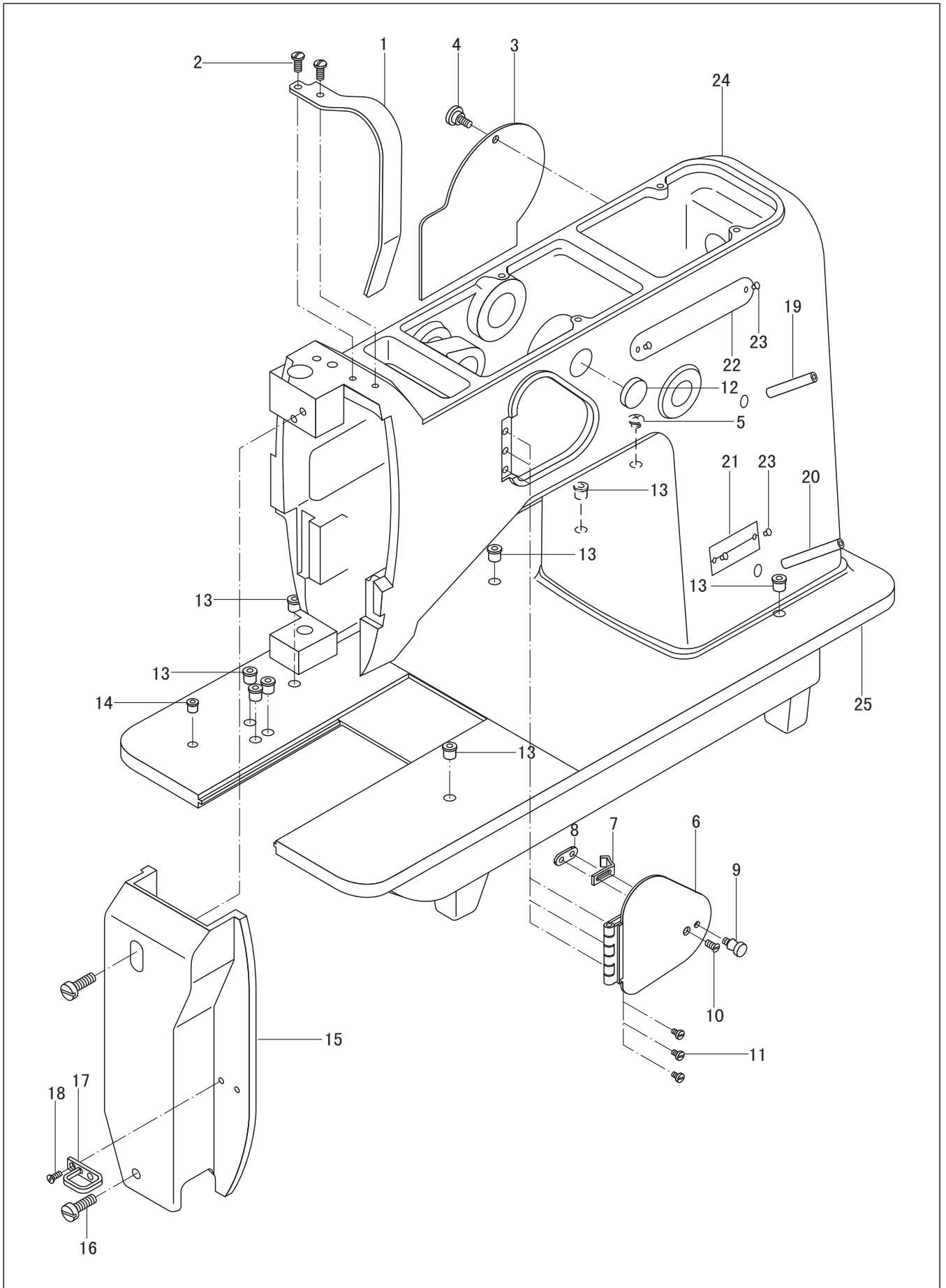

1. Machine casting components

No.	Parts No.	Name of parts	Qty.			Remarks
			6BR	6BR-3	6BR-4	
1	6K4-017	Thread take-up lever cover	1	1	1	
2	49WF2-012	Screw	2	2	2	
3	17KT-003	back cover	1	1	1	
4	6K4-030	Screw	1	1	1	
5	2KT6-017	Screw	1	1	1	
6	17KT1-004	Zigzag adjuster cover	1	1	1	SM9/64" 4 0
7	17KT1-005	Cover spring	1	1	1	
8	17KT1-006	Spring stopper	1	1	1	SM9/64" 40
9	17KT1-007	Thumb screw	1	1	1	M4 0.7
10	22WF2-007	Screw	1	1	1	
11	89WF2-005	Screw	3	3	3	
12	17KT1-008	Rubber plug	1	1	1	
13	17KT1-009	Oil cup(big)	8	8	8	SM9/64" 40
14	6K4-046	Oil cup(small)	1	1	1	SM9/64" 4 0
15	17KT1-010	Face plate	1	1	1	SM1/8" 4 4
16	6K4-004	Screw	2	2	2	
17	16WF2-011	Thread guide	1	1	1	
18	16WF2-015	Screw	1	1	1	
19	17KT1-031	Oil tube(Short)	1	1	1	
20	17KT1-032	Oil tube(long)	1	1	1	SM15/64" 28
21	17KT1-030A	Model label			1	
	17KT1-030B	Model label			1	SM9/64" 4 0
	22KT1-001A	Model label		1		
	22KT1-001B	Model label		1		
	23KT1-001A	Model label	1			
	23KT1-001B	Model label	1			
	24KT1-001A	Model label				
	24KT1-001B	Model label				
	25KT1-001A	Model label				
	25KT1-001B	Model label				
	26KT1-001A	Model label				TW7-6B
	26KT1-001B	Model label				TW7-6B
22	16WF2-051	Brandlabel	1	1	1	TW7-6B-3
23	17KT1-001	Arm	1	1	1	TW7-6B-3
24	17KT1-002	bed	1	1	1	TW7-6B-4
25		Rivet	4	4	4	TW7-6B-4

2.Upper shaft mechanism

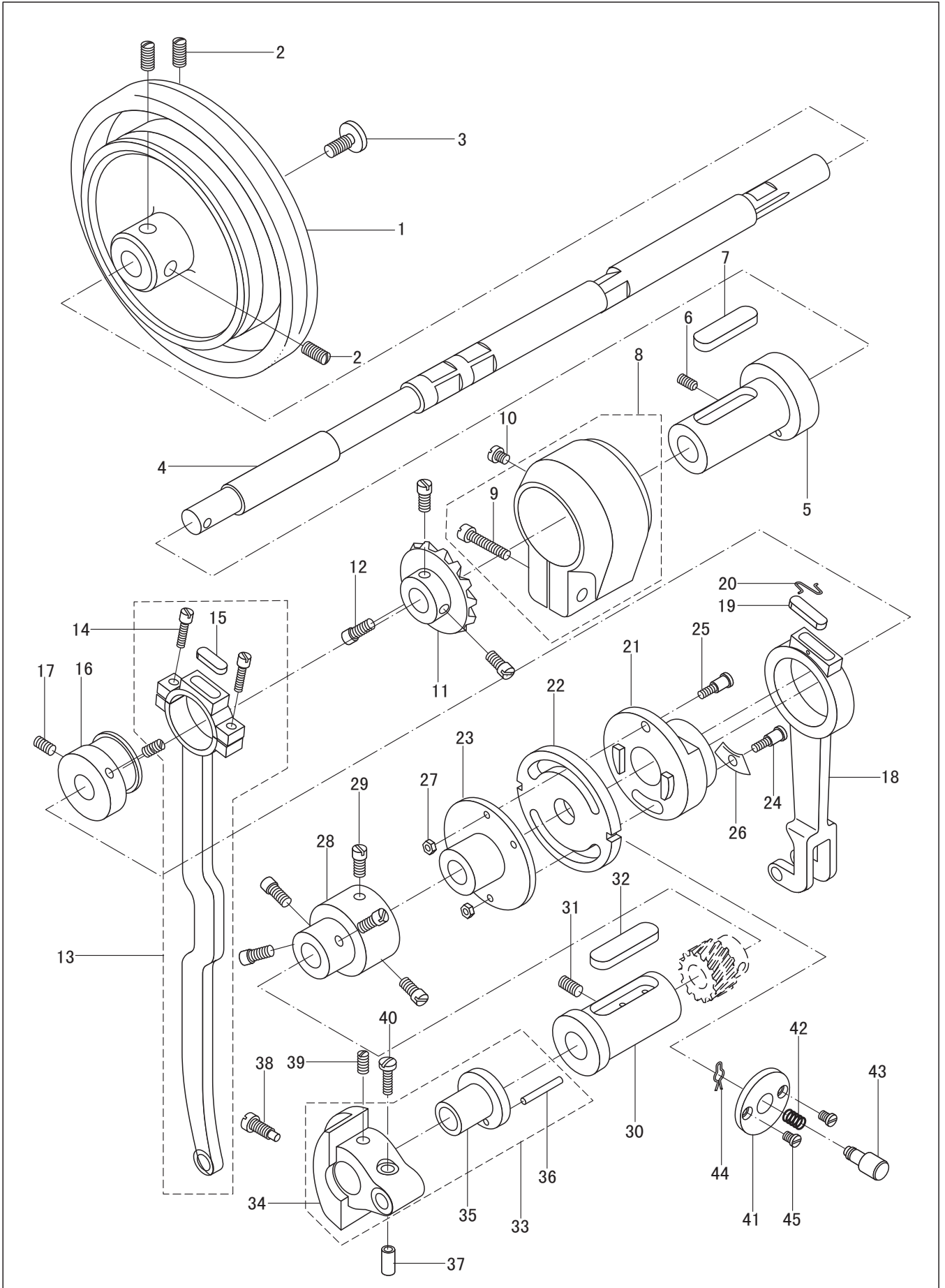

2.Upper shaft mechanism

No.	Parts No.	Name of parts	Qty.			Remarks
			6BR	6BR-3	6BR-4	
1	6K1-040	Hand wheel	1	1	1	
2	6K1-041	Screw	3	3	3	
3	6K1-042	Screw	1	1	1	
4	17KT2-001	Upper shaft	1	1	1	
5	6K1-031	Upper shaft bush(right)	1	1	1	
6	6K1-034	Screw	1	1	1	SM5/16" 2 4
7	6K1-033	Felt	1	1	1	SM5/16" 24
8	6K1-037	Gear cover	1	1	1	
9	6K1-038	Screw	1	1	1	
10	6K1-039	Screw	1	1	1	SM15/64" 28
11	17KT2-002	Bevel gear	1	1	1	
12	6K1-036	Screw	3	3	3	
13	6K2-014	Feed lifting connecting rod	1	1	1	SM9/32" 20
14	6K2-015	Screw	2	2	2	SM1/4" 28
15	6K2-011	Felt	1	1	1	
16	6K2-013	Feed lifting eccentric	1	1	1	SM1/4" 4 0
17	6K1-017	Screw	2	2	2	
18	6K2-010	Feed connecting rod	1	1	1	SM3/16" 28
19	6K2-011	Felt	1	1	1	
20	6K2-012	Oil felt stopper	1	1	1	
21	6K2-001	Feed eccentric	1	1	1	
22	6K2-002	Feed eccentric adjusting disc	1	1	1	
23	6K2-003	Feed eccentric adjusting flange	1	1	1	
24	6K2-004	Screw	1	1	1	
25	6K2-006	Screw	1	1	1	
26	6K2-005	Washer	1	1	1	
27	6K2-007	Nut	2	2	2	
28	6K2-008	Flange coupling	1	1	1	SM3/16" 3 2
29	6K2-009	Screw	3	3	3	SM3/16" 3 2
30	6K1-029	Upper shaft bush(left)	1	1	1	
31	6K1-030	Screw	1	1	1	SM3/16" 32
32	6K1-033	Felt	1	1	1	
33	17KT2-003	Needle bar crank assembly	1	1	1	SM1/4" 40
34	17KT2-003A	Needle bar crank	1	1	1	
35	17KT2-003B	Needle bar crank bush	1	1	1	SM9/32" 2 8
36	17KT2-003C	Pin	1	1	1	
37	6K1-023	Pin	1	1	1	
38	6K1-027	Screw	1	1	1	
39	6K1-026	Screw	1	1	1	
40	6K1-024	Screw	1	1	1	
41	17KT2-004	Regulating stud socket	1	1	1	
42	17KT2-005	Spring	1	1	1	SM9/32" 2 8
43	17KT2-006	Push button	1	1	1	SM9/32" 2 8
44	17KT2-007	Cotter pin	1	1	1	SM3/16" 3 2
45	17KT2-008	Screw	2	2	2	

3.Vertical shaft and hook mechanism

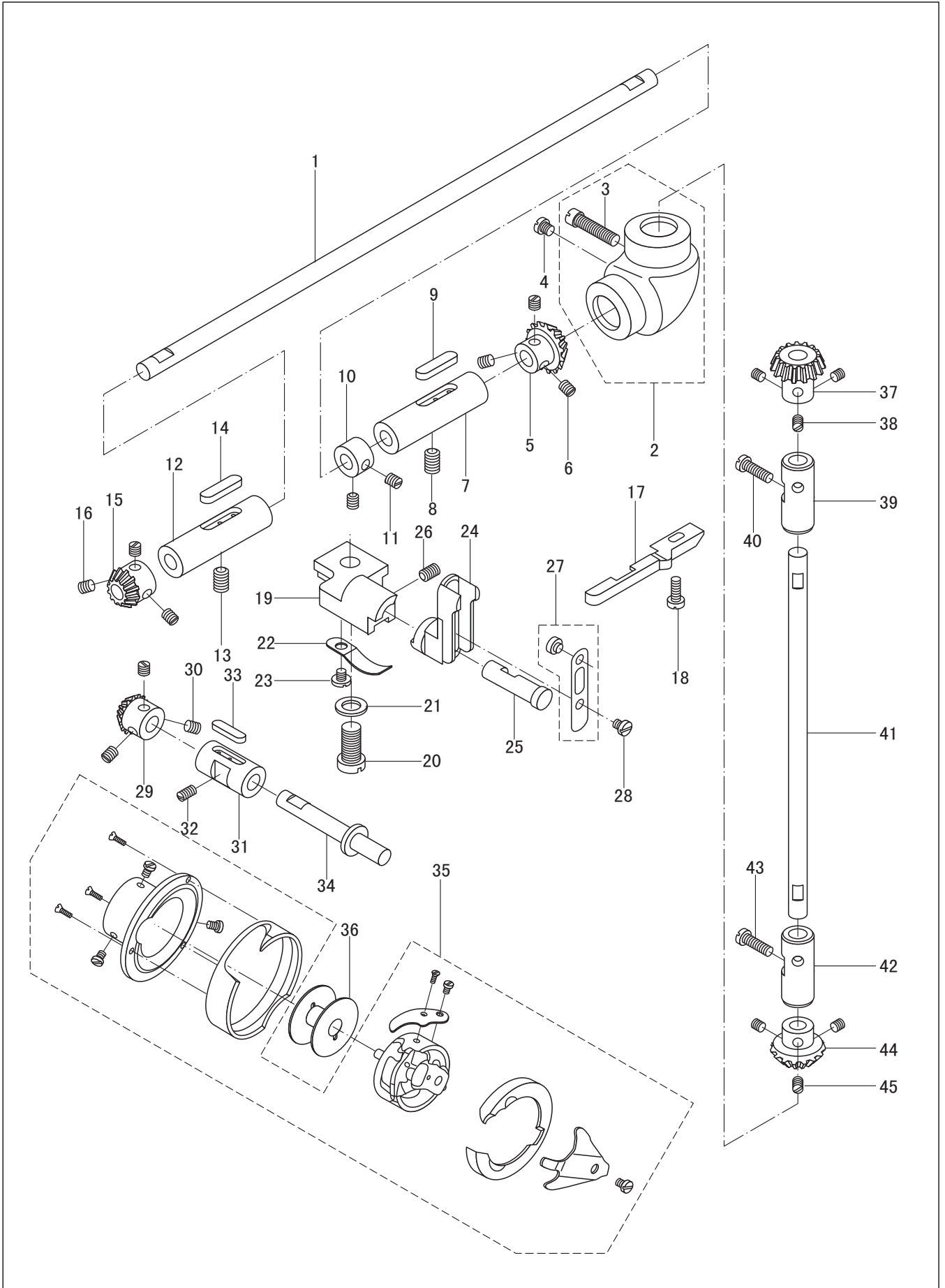

3.Vertical shaft and hook mechanism

No.	Parts No.	Name of parts	Qty.			Remarks
			6BR	6BR-3	6BR-4	
1	17KT3-001	Lower shaft	1	1	1	
2	6K1-050	Gear cover	1	1	1	
3	6K1-038	Screw	1	1	1	
4	6K1-039	Screw	1	1	1	
5	17KT3-002	Bevel gear	1	1	1	
6	6K1-044	Screw	3	3	3	
7	6K1-053	Lower shaft bush (right)	1	1	1	SM9/32" 2 0
8	17KT3-003	Screw	1	1	1	SM1/4" 28
9	17KT3-004	Oil felt	1	1	1	
10	6K1-054	Collar	1	1	1	SM1/4" 40
11	6K1-008	Screw	2	2	2	
12	17KT3-005	Lower shaft bush(left)	1	1	1	SM5/16" 24
13	6K1-041	Screw	1	1	1	
14	17KT3-004	Oil felt	1	1	1	
15	17KT3-006	Hook driving gear	1	1	1	SM15/64" 28
16	6K1-044	Screw	3	3	3	
17	17KT3-007	Hook retainer	1	1	1	SM5/16" 2 4
18	6K1-057	Screw	1	1	1	
19	17KT3-008	Hook retainer bracket	1	1	1	
20	6K1-059	Screw	1	1	1	SM1/4" 40
21		Washer	1	1	1	
22	6K1-062	Position spring	1	1	1	SM11/64" 4 0
23	6K1-063	Screw	1	1	1	
24	6K1-060	Bobbin case retainer	1	1	1	SM5/16" 2 8
25	6K1-061	Hinge stud	1	1	1	GB93 8
26	6K1-065	Screw	1	1	1	
27	6K1-064	Retainer spring	1	1	1	SM11/64" 40
28	6K1-004	Screw	1	1	1	
29	17KT3-028	Hook shaft gear	1	1	1	
30	6K1-044	Screw	3	3	3	SM15/64" 28
31	17KT3-009	Hook shaft bushing	1	1	1	
32	6K1-065	Screw	1	1	1	SM9/64" 4 0
33	17KT3-004	Oil felt	1	1	1	
34	17KT3-010	Hook shaft	1	1	1	SM1/4" 4 0
35	17KT3-011	Hook assembly	1	1	1	
36	6K6-008	Bobbin	1	1	1	SM15/64" 2 8
37	17KT3-012	Vertical shaft gear(upper)	1	1	1	
38	6K1-044	Screw	3	3	3	
39	6K1-046	Vertical shaft bush(upper)	1	1	1	
40	16WF3-061	Screw	1	1	1	
41	6K1-045	Vertical shaft	1	1	1	
42	6K1-047	Vertical shaft bush (lower)	1	1	1	SM1/4" 4 0
43	16WF3-061	Screw	1	1	1	
44	17KT3-029	Vertical shaft gear(lower)	1	1	1	SM15/64" 2 8
45	6K1-044	Screw	3	3	3	

4. Needle bar rocking frame and presser bar mechanism

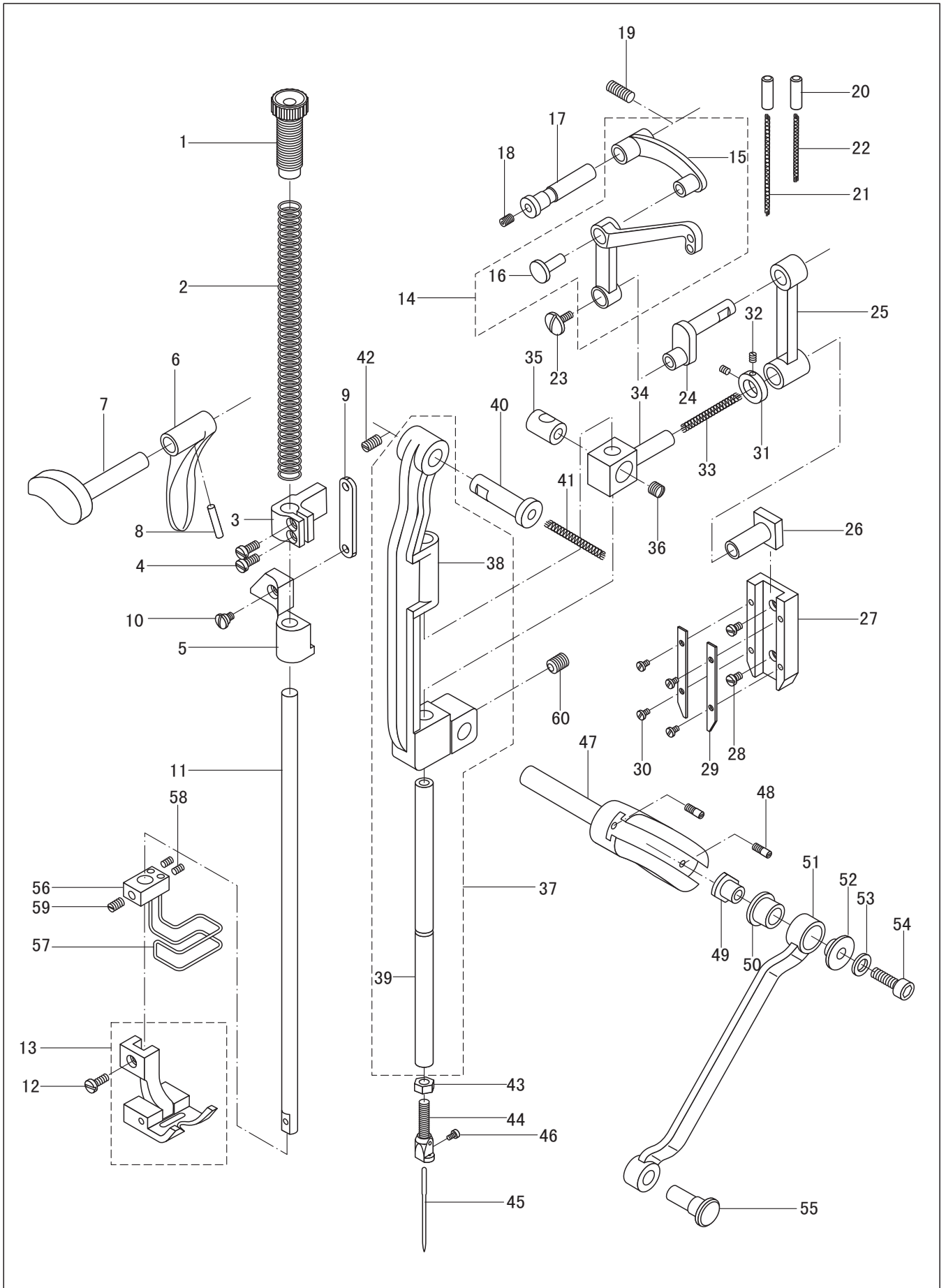

4. Needle bar rocking frame and presser bar mechanism

No.	Parts No.	Name of parts	Qty.			Remarks
			6BR	6BR-3	6BR-4	
1	6K3-009	Presser bar thumb screw	1	1	1	
2	17KT5-001	Presser bar spring	1	1	1	
3	17KT5-002	Presser bar bracket(1)	1	1	1	
4	6K3-014	Screw	2	2	2	
5	6K3-018	Presser bar bracket(2)	1	1	1	
6	6K3-024	Presser foot lifting lever	1	1	1	
7	6K3-023	Presser foot lifter	1	1	1	
8		Taper pin	1	1	1	SM3/16" 3 2
9	6K3-019	Lifting lever link	1	1	1	
10	6K3-020	Screw	1	1	1	
11	6K3-012	Presser bar	1	1	1	
12	17KT5-003	Presser foot	1	1	1	GB/T 117 3 12
13	22WF24-014	Screw	1	1	1	
14	17KT4-035	Thread take-up lever	1	1	1	SM3/16" 32
15	6K1-015	Thread take-up lever link	1	1	1	
16	6K1-020	Thread take-up pin	1	1	1	
17	6K1-016	Thread take-up lever link pin	1	1	1	SM11/64" 40
18	6K1-018	Screw	1	1	1	
19	6K1-017	Screw	1	1	1	
20	17KT4-001	Oil pipe	2	2	2	
21		Oil wick(long)	1	1	1	
22		Oil wick(short)	1	1	1	SM11/64" 40
23	6K1-021	Screw	1	1	1	SM15/64" 2 8
24	17KT4-002	Thread take-up crank	1	1	1	
25	17KT4-003	Needle bar link	1	1	1	
26	17KT4-004	Stud guide block	1	1	1	
27	17KT4-005	Stud guide	1	1	1	SM11/64" 40
28	6K1-014	Screw	2	2	2	
29	17KT4-006	Guide plate	1	1	1	
30	6K2-052	Screw	4	4	4	
31	17KT4-007	Collar	1	1	1	
32	17KT4-008	Screw	2	2	2	SM9/64" 4 0
33		Oil wick	1	1	1	
34	17KT4-009	Needle bar connecting stud	1	1	1	SM3/32" 5 6
35	17KT4-010	Needle bar holder	1	1	1	
36	17KT4-035	Screw	1	1	1	M3 0.5
37		Needle bar rocking frame assembly	1	1	1	
38	17KT4-011	Needle bar rocking frame	1	1	1	
39	17KT4-012	Needle bar	1	1	1	
40	17KT4-013	Hinge stud	1	1	1	SM1/4" 32
41		Oil wick	1	1	1	
42	6K1-017	Screw	1	1	1	
43	16WF3-021	Nut	1	1	1	
44	17KT4-014	Needle clamp	1	1	1	
45	17KT4-034	Needle	1	1	1	
46	17KT4-015	Screw	1	1	1	
47	17KT4-016	Zigzag eccentric shaft	1	1	1	
48	6K3-007	screw	2	2	2	
49	17KT4-017	Zigzag connecting block	1	1	1	DDXH14 25#
50	17KT4-018	Zigzag connecting collar	1	1	1	SM9/64" 3 6
51	17KT4-019	Zigzag connection	1	1	1	
52	17KT4-020	Disc	1	1	1	SM9/64" 4 0
53		Washer	1	1	1	
54	6K2-024	Screw	1	1	1	
55	17KT4-021	Hinge pin	1	1	1	
56	17KT5-004	Finger guard base	1	1	1	
57	17KT5-005	Finer guard	1	1	1	GB/T 97.1 6
58	17KT5-018	Screw	2	2	2	M6 1
59	6K1-008	Screw	1	1	1	
60	16WF3-032	Screw	1	1	1	

5. Needle plate and bottom feed mechanism

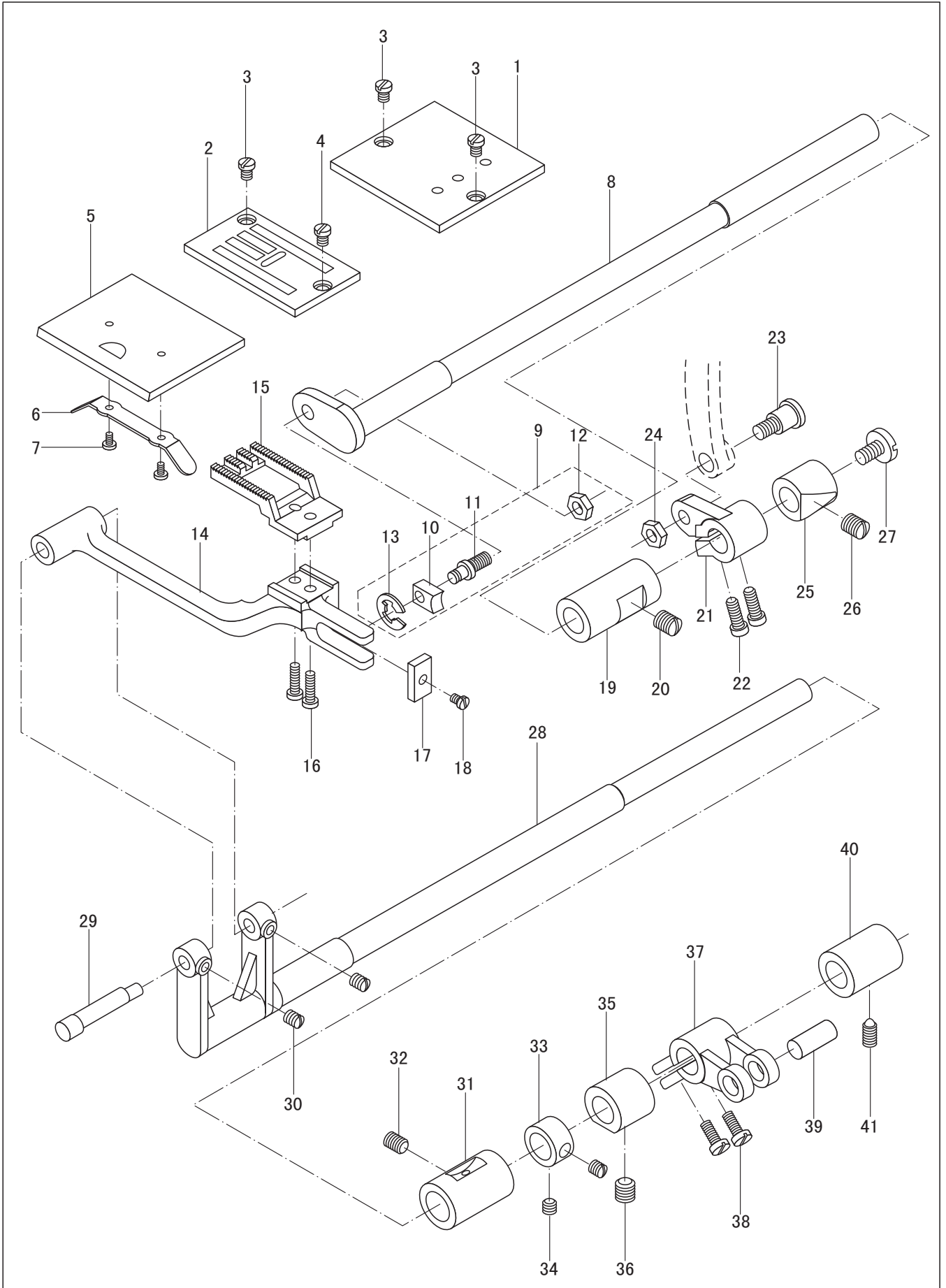

5. Needle plate and bottom feed mechanism

No.	Parts No.	Name of parts	Qty.			Remarks
			6BR	6BR-3	6BR-4	
1	17KT3-013	Slide plate(right)	1	1	1	
2	17KT3-014	Needle plate	1	1	1	
3	6K4-033	Screw	3	3	3	
4	17KT3-027	Screw	1	1	1	
5	17KT3-015	Slide plate(left)	1	1	1	
6	6K4-036	Slide plate spring	1	1	1	
7	6K4-052	Screw	2	2	2	SM3/16" 2 8
8	17KT3-016	Feed lifting shaft	1	1	1	SM3/16" 28
9		Slide block complete	1	1	1	
10	6K2-062	Slide block	1	1	1	
11	6K2-063	Screw	1	1	1	
12	6K2-064	Nut	1	1	1	
13		Retainer ring	1	1	1	
14	17KT3-017	Feed bar	1	1	1	
15	17KT3-018	Feed dog	1	1	1	SM9/32" 28
16	17KT3-019	Screw	2	2	2	
17	17KT3-020	Oil felt	1	1	1	GB896 4
18	6K2-052	Screw	1	1	1	
19	6K2-061	Feed lifting shaft bush(left)	1	1	1	
20	17KT3-003	Screw	1	1	1	SM9/64" 40
21	17KT3-021	Feed lifting crank	1	1	1	
22	6K2-015	Screw	2	2	2	SM3/32" 5 6
23	6K2-056	Screw	1	1	1	
24	6K2-057	Nut	1	1	1	SM5/16" 24
25	6K2-060	Feed lifting shaft bush(right)	1	1	1	
26	17KT3-003	screw	1	1	1	SM3/16" 2 8
27	6K2-059	Screw	1	1	1	SM9/32" 2 8
28	17KT3-022	Feed shaft	1	1	1	SM9/32" 2 8
29	17KT3-023	Hinge pin	1	1	1	
30	6K5-028	Screw	2	2	2	SM5/16" 2 4
31	17KT3-024	Feed shaft bush(left)	1	1	1	SM1/4" 4 0
32	6K1-041	Screw	1	1	1	
33	17KT3-025	Feed shaft collar	1	1	1	
34	6K1-008	Screw	2	2	2	SM7/32" 3 2
35	17KT3-026	Feed shaft bush (middle)	1	1	1	
36	6K1-041	Screw	1	1	1	SM5/16" 2 4
37	6K2-045	Feed crank	1	1	1	
38	6K1-048	Screw	2	2	2	SM15/64" 2 8
39	6K2-046	Pin	1	1	1	
40	6K2-048	Feed shaft(right)	1	1	1	SM5/16" 2 4
41	6K1-041	Screw	1	1	1	SM15/64" 2 8

SM5/16" 2 4

6. Thread tension and presser foot lifting mechanism

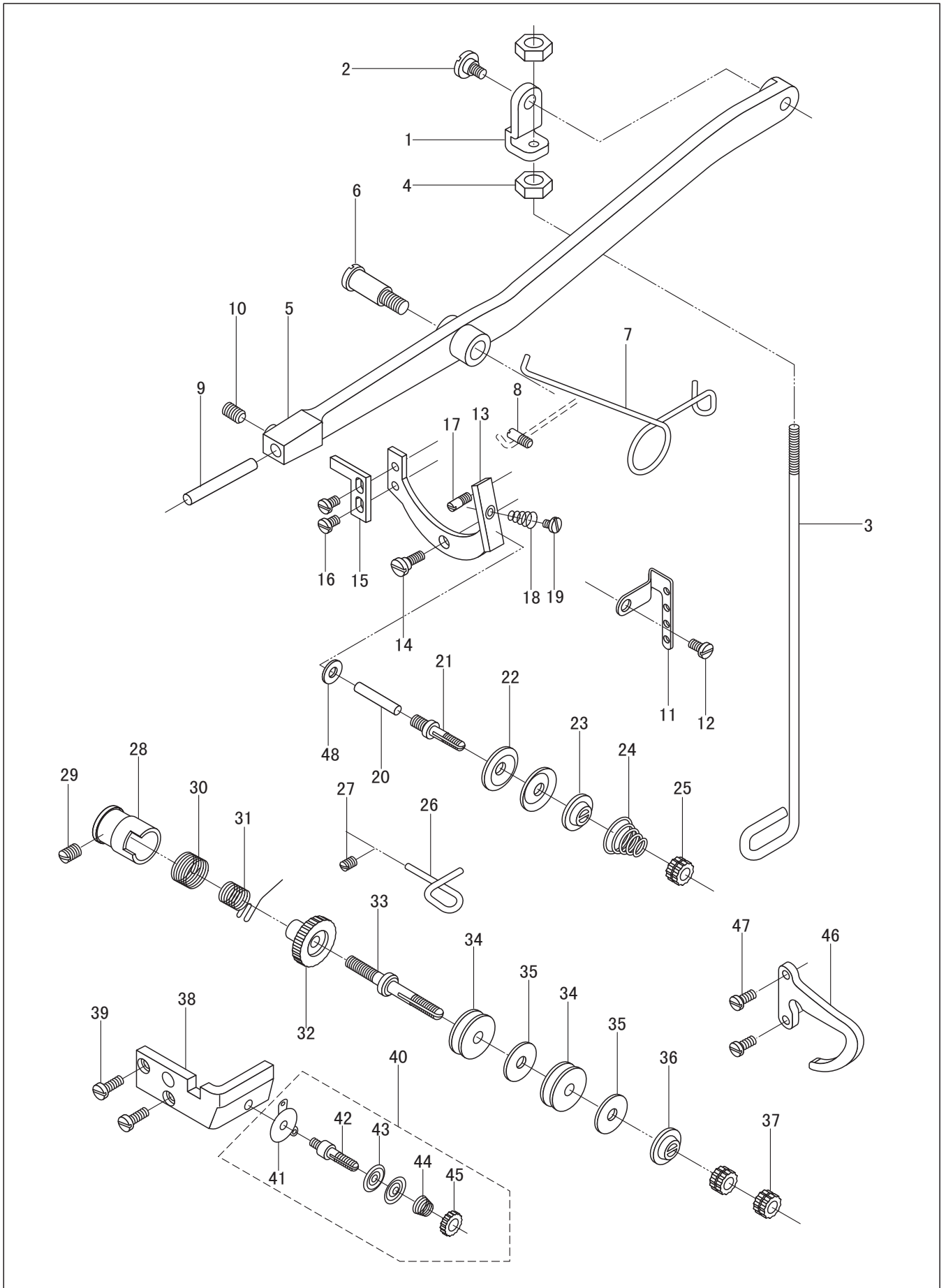

6.Thread tension and presser foot lifting mechanism

No.	Parts No.	Name of parts	Qty.			Remarks
			6BR	6BR-3	6BR-4	
1	6K3-002	Joint	1	1	1	
2	6K2-003	Screw	1	1	1	
3	17KT5-006	Connecting rod	1	1	1	
4	6K2-007	Nut	2	2	2	
5	17KT5-007	Foot lifting lever	1	1	1	
6	6K3-008	Screw	1	1	1	SM15/64" 2 8
7	6K3-006	Spring	1	1	1	
8	6K3-007	Screw pin	1	1	1	SM3/16" 32
9	6K3-005	Pin	1	1	1	
10	6K1-065	Screw	1	1	1	SM5/16" 24
11	17KT1-011	Thread guide	1	1	1	
12	22WF6-007	Screw	1	1	1	SM9/64" 40
13	17KT1-012	Tension release lever	1	1	1	
14	17KT1-013	Screw	1	1	1	SM15/64" 2 8
15	17KT1-014	Tension release lever support	1	1	1	
16	6K1-004	Screw	2	2	2	SM7/32" 32
17	6K3-007	Screw pin	1	1	1	
18	17KT1-015	Spring	1	1	1	SM3/16" 2 8
19	89WF2-005	Screw	1	1	1	
20	17KT1-016	Tension release pin	1	1	1	
21	17KT1-017	Tension screw stud(upper)	1	1	1	SM9/64" 4 0
22	22T1-012F5	Tension disc(upper)	2	2	2	
23	6K4-019	Tension release washer	1	1	1	SM1/8" 4 4
24	6K4-027	Thread tension spring	1	1	1	
25	6K4-022	Thread tension nut	1	1	1	
26	6K4-023	Thread guide	1	1	1	
27	6K1-018	Screw	1	1	1	
28	17KT1-019	Thread take-up spring regulator	1	1	1	
29	6K1-017	Screw	1	1	1	
30	6K4-015	Regulating spring	1	1	1	
31	17KT1-020	Thread take-up spring	1	1	1	SM11/64" 4 0
32	6K4-016	Adjusting sleeve	1	1	1	
33	6K4-013	Tension screw stud(lower)	1	1	1	SM15/64" 2 8
34	17KT1-021	Tension disc	2	2	2	
35	17KT1-022	Disc leather	2	2	2	
36	6K4-019	tension release washer	1	1	1	
37	6K4-022	Tension thumb nut	2	2	2	
38	17KT1-023	Needle bar rocking frame guide	1	1	1	
39	13WF2-063	Screw	2	2	2	
40	17KT1-035	Auxiliary tension regulator complete	1	1	1	
41	17KT1-024	Thread guide	1	1	1	
42	17KT1-025	Auxiliary tension screw stud	1	1	1	
43	22T1-009E3	Auxiliary tension disc	2	2	2	SM11/64" 3 2
44	13WF2-009	Auxiliary tension spring	1	1	1	
45	36T2-006D4	Auxiliary tension thumb nut	1	1	1	
46	17KT1-026	Thread guide	1	1	1	
47	6K4-011	Screw	2	2	2	
48	17KT1-018	Washer	1	1	1	

7.Reverse feed mechanism

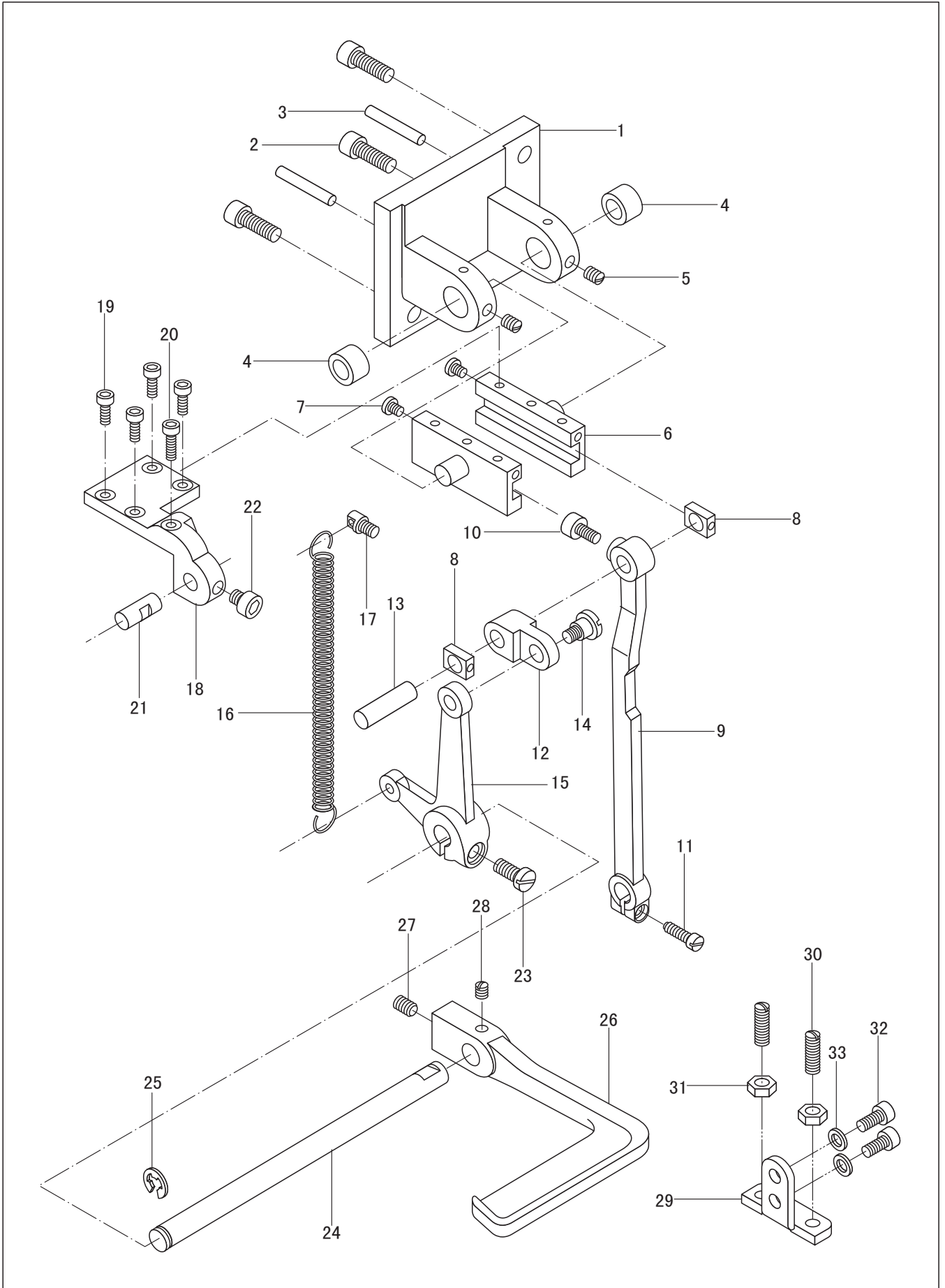

7.Reverse feed mechanism

No.	Parts No.	Name of parts	Qty.			Remarks
			6BR	6BR-3	6BR-4	
1	17KT2-013	Slide block guide base	1	1	1	
2	6K2-024	Screw	3	3	3	
3		Taper pin	2	2	2	
4		needle bearing	2	2	2	
5	6K1-018	Screw	2	2	2	
6	6K2-021	Slide block guide	2	2	2	M6 1
7	6K2-022	Screw	2	2	2	GB/T 117 4 26
8	6K2-025	Slide block	2	2	2	$\phi 14.29$ $\phi 9.52$ 9.4
9	6K2-044	Feed shaft connecting rod(lower)	1	1	1	SM11/64" 4 0
10	6K2-018	Screw	1	1	1	
11	6K2-015	Screw	1	1	1	M4 07
12	6K2-027	Link	1	1	1	
13	6K2-026	Connecting pin	1	1	1	
14	6K2-028	Screw	1	1	1	SM13/64" 3 2
15	6K2-029	Feed reversing lever shaft crank	1	1	1	SM3/16" 2 8
16	6K2-031	Feed reversing lever spring	1	1	1	
17	6K2-032	Spring hook	1	1	1	
18	6K2-016	Slide block guide plate	1	1	1	SM15/64" 2 8
19	6K2-019	Screw	4	4	4	
20	6K2-020	Screw	1	1	1	
21	6K2-017	Pin	1	1	1	M5 8
22	6K2-018	Screw	1	1	1	
23	6K2-030	Screw	1	1	1	M4 0 . 7
24	17KT2-009	Feed reversing lever shaft	1	1	1	M4 0 . 7
25		Retainer ring	1	1	1	
26	17KT2-010	Feed reversing lever	1	1	1	M5 0 . 8
27	6K2-042	Screw	1	1	1	SM3/16" 2 8
28	6K2-043	Screw	1	1	1	
29	17KT2-011	Stopper	1	1	1	GB896 6
30	6K2-039	Screw	2	2	2	
31	6K2-040	Nut	2	2	2	M6 1
32	17KT2-012	Screw	2	2	2	M5 0 . 8
33		Washer	2	2	2	SM15/64" 2 8 SM15/64 2 8 M5 0 . 8 GB93 5

8.Feed clutch mechanism

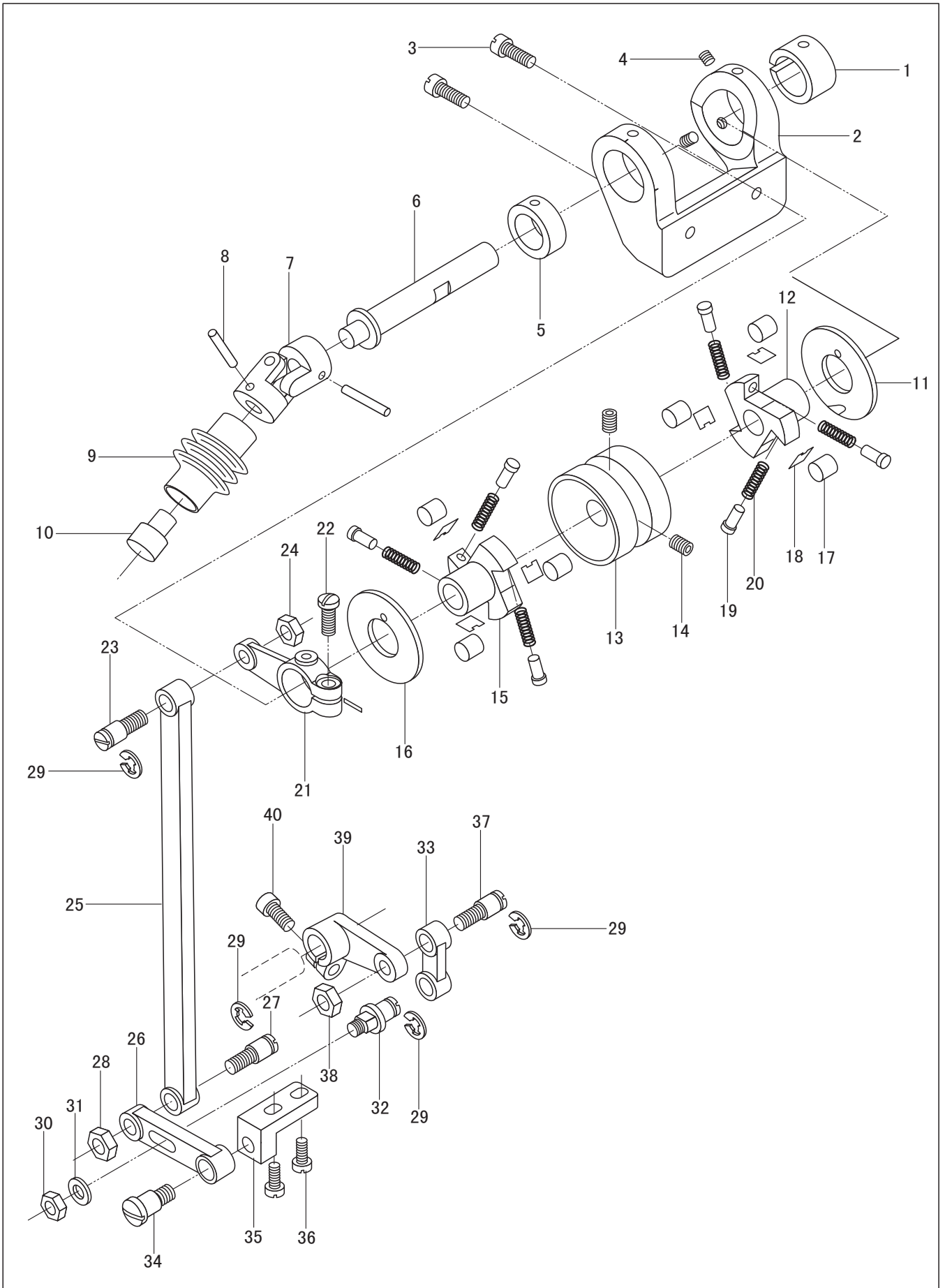

8.Feed clutch mechanism

No.	Parts No.	Name of parts	Qty.			Remarks
			6BR	6BR-3	6BR-4	
1	17KT6-001	Feed clutch bushing(right)	1	1	1	
2	17KT6-002	Feed clutch fork	1	1	1	
3	6K1-048	Screw	2	2	2	
4	6K1-065	Screw	2	2	2	
5	17KT6-003	Feed clutch bushing(Left)	1	1	1	
6	17KT6-006	Feed clutch shaft	1	1	1	
7	17KT6-004	Universal joint complete	1	1	1	SM15/64" 2 8
8		Pin	2	2	2	SM15/64" 28
9	17KT6-005	Rubber cover	1	1	1	
10	17KT6-007	Short shaft	1	1	1	
11	17KT6-010	Feed clutch washer	1	1	1	
12	17KT6-011	Feed clutch (back)	1	1	1	GB879. 1 3 20
13	17KT6-012	Feed clutch body	1	1	1	
14	80WF6-018	Screw	1	1	1	
15	17KT6-013	Feed clutch (Front)	1	1	1	
16	17KT6-010	Feed clutch washer	1	1	1	
17	17KT6-014	Feed clutch roller	6	6	6	
18	17KT6-015	Feed clutch roller guide	6	6	6	SM1/4" 28
19	17KT6-016	Feed clutch pin	6	6	6	
20	17KT6-017	Spring	6	6	6	
21	17KT6-018	Feed clutch crank(upper)	1	1	1	
22	6K1-048	Screw	1	1	1	
23	17KT6-019	Screw	1	1	1	
24	6K5-034	Nut	1	1	1	
25	17KT6-020	Connecting rod (big)	1	1	1	
26	17KT6-021	Connecting rod (small)	1	1	1	
27	17KT6-019	Screw	1	1	1	SM17/64" 3 2
28	6K5-034	Nut	1	1	1	SM17/64" 32
29		Retaining ring	4	4	4	
30	22WF3-004	Nut	1	1	1	
31		Washer	1	1	1	SM17/64" 3 2
32	17KT6-022	Screw block	1	1	1	SM17/64" 3 2
33	17KT6-023	Connecting link	1	1	1	GB896 6
34	6K2-056	Screw	1	1	1	GB/T 97. 1 6
35	17KT6-024	Bracket	1	1	1	
36	6K3-014	Screw	2	2	2	
37	17KT6-019	Screw	1	1	1	SM9/32" 2 8
38	6K5-034	Nut	1	1	1	
39	17KT6-025	Feed clutch crank(lower)	1	1	1	SM3/16" 3 2
40	53WF2-009	Screw	1	1	1	SM17/64" 3 2 SM17/64" 3 2 M6 1

9.Puller mechanism

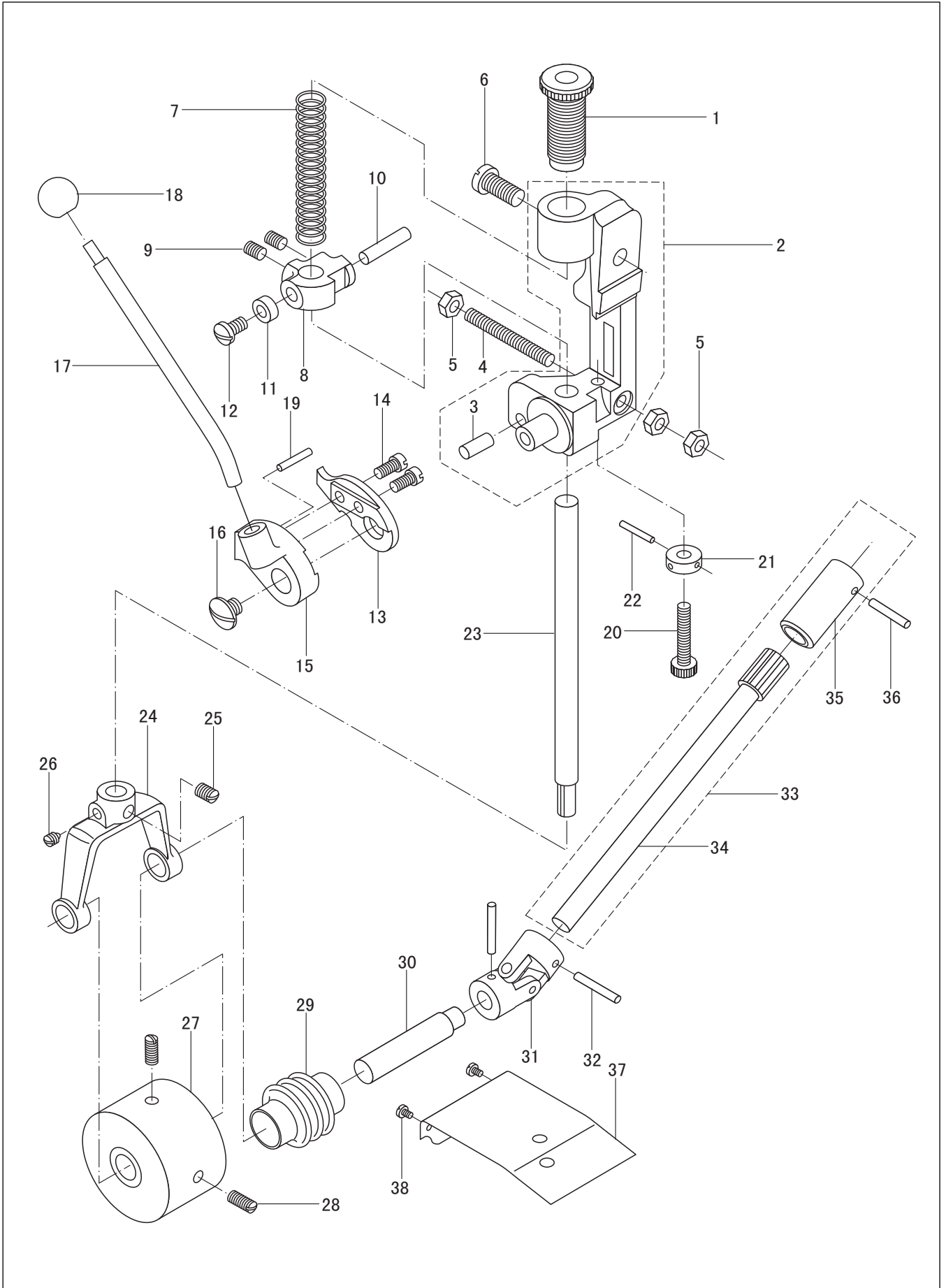

9.Puller mechanism

No.	Parts No.	Name of parts	Qty.			Remarks
			6BR	6BR-3	6BR-4	
1	17KT6-026	Thumb screw	1	1	1	
2	17KT6-027	Puller arm	1	1	1	
3		Pin	1	1	1	
4	17KT6-028	Screw	1	1	1	
5	22WF3-004	Nut	1	1	1	SM11/16" 2 8
6	6K1-059	Screw	1	1	1	
7	17KT6-029	Puller presser bar spring	1	1	1	
8	17KT6-030	Puller presser bar baracket	1	1	1	SM15/64" 28
9	16WF6-053	Screw	2	2	2	SM15/64" 28
10	17KT6-031	Guide pin	1	1	1	SM5/16" 2 8
11	17KT6-032	Roller	1	1	1	
12	17KT6-033	Screw	1	1	1	
13	17KT6-034	Puller lifting lever guide plate	1	1	1	SM1/4" 32
14	17KT6-035	Screw	2	2	2	
15	17KT6-036	Puller lifting lever bracket	1	1	1	
16	17KT6-037	Screw	1	1	1	SM1/4" 3 2
17	17KT6-038	Roller lifting lever	1	1	1	
18	17KT6-039	Roller lifting lever knob	1	1	1	SM15/64" 3 2
19		Taper pin	1	1	1	
20	17KT6-040	Screw	1	1	1	SM17/64" 2 4
21	17KT6-041	Collar	1	1	1	
22		Tape pin	1	1	1	
23	17KT6-042	Puller presser bar	1	1	1	GB/T 117 3 1 2
24	17KT6-043	Puller fork	1	1	1	SM1/4" 3 2
25	16WF1-053	Screw	1	1	1	
26	16WF1-054	Screw	1	1	1	GB/TS 117 3 1 8
27	17KT6-044	Puller complete	1	1	1	
28	6K1-034	Screw	2	2	2	
29	17KT6-005	Rubber cover	1	1	1	SM1/4" 3 2
30	17KT6-045	Puller shaft	1	1	1	SM1/4" 3 2
31	17KT6-004	Universal joint complete	1	1	1	
32		Pin	2	2	2	
33		Spline shaft complete	1	1	1	
34	17KT6-009	Spline shaft	1	1	1	
35	17KT6-008	Spline shaft connection	1	1	1	
36		Pin	1	1	1	GB879. 1 3 2 0
37	17KT6-046	Puller bed plate	1	1	1	
38	89WF2-005	Screw	2	2	2	
						GB879. 1 3 2 0
						SM1/8" 4 4

10. Zigzag gear and upper cover mechanism(-6BR-3/-6BR-4)

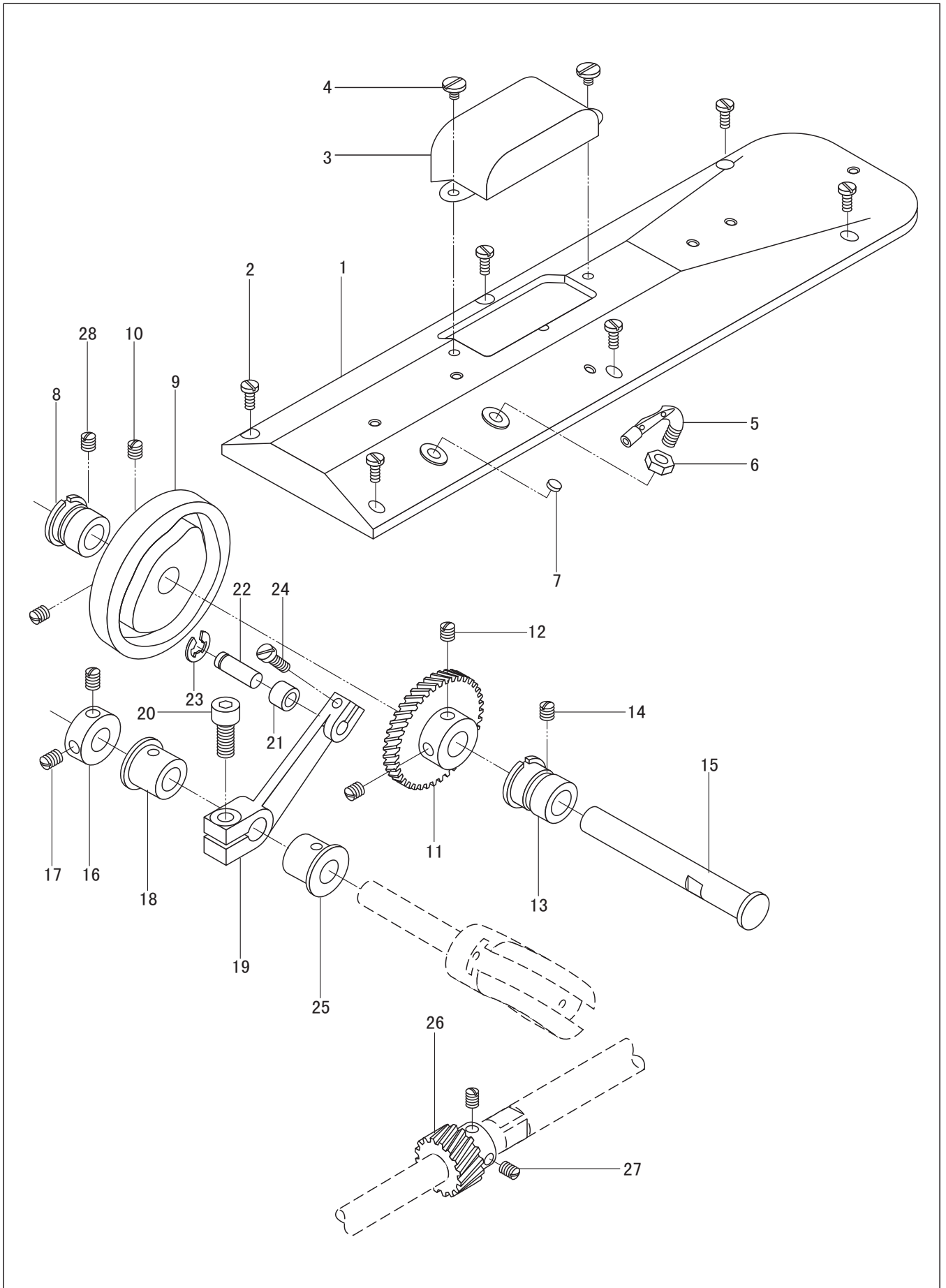

10.Zigzag gear and upper cover mechanism(-6BR-3/-6BR-4)

No.	Parts No.	Name of parts	Qty.			Remarks
			6BR	6BR-3	6BR-4	
1	17KT1-027	Upper cover		1	1	
2	49WF2-012	Screw	6	6	6	
3	17KT1-028	Auxiliary cover		1	1	
4	16WF2-044	Screw		2	2	
5	13WF2-066	Thread guide	1	1	1	
6	13WF2-067	Nut	1	1	1	SM9/64" 4 0
7	17KT1-029	Rubber plug	1	1	1	
8	17KT4-022	Zigzag shaft bushing(back)		1	1	
9	17KT4-023	Zigzag eccentric			1	
	22KT2-001	Zigzag eccentric		1		
10	16WF1-053	Screw	2	2	2	
11	17KT4-024	Zigzag gear(big)			1	
	22KT2-002	Zigzag gear(big)		1		
12	7KT3-033	Screw	2	2	2	
13	17KT4-026	Zigzag shaft bushing(front)	1	1	1	SM1/4" 32
14	6K1-065	Screw	1	1	1	
15	17KT4-027	Zigzag shaft	1	1	1	
16	17KT4-028	Collar	1	1	1	SM1/4" 40
17	16WF1-053	Screw	1	1	1	
18	17KT4-029	Bushing(back)	1	1	1	SM15/64" 2 8
19	17KT4-030	Zigzag eccentric connection		1	1	
20	17KT4-031	Screw	1	1	1	
21	17KT4-032	Roller		1	1	SM1/4" 32
22	17KT4-033	Roller pin		1	1	
23		Cotter ring		1	1	
24	6K1-024	Screw		1	1	M8 1 . 25
25	17KT4-029	Bushing (front)	1	1	1	
26	17KT4-025	Zigzag gear(small)			1	
	22KT2-003	Zigzag gear(small)		1		GB896 5 发黑
27	21WF1-043	Screw	2	2	2	SM3/16" 3 2
28	13WF6-018	Screw	1	1	1	
						SM11/64" 4 0

10. Zigzag gear and upper cover mechanism(-6BR)

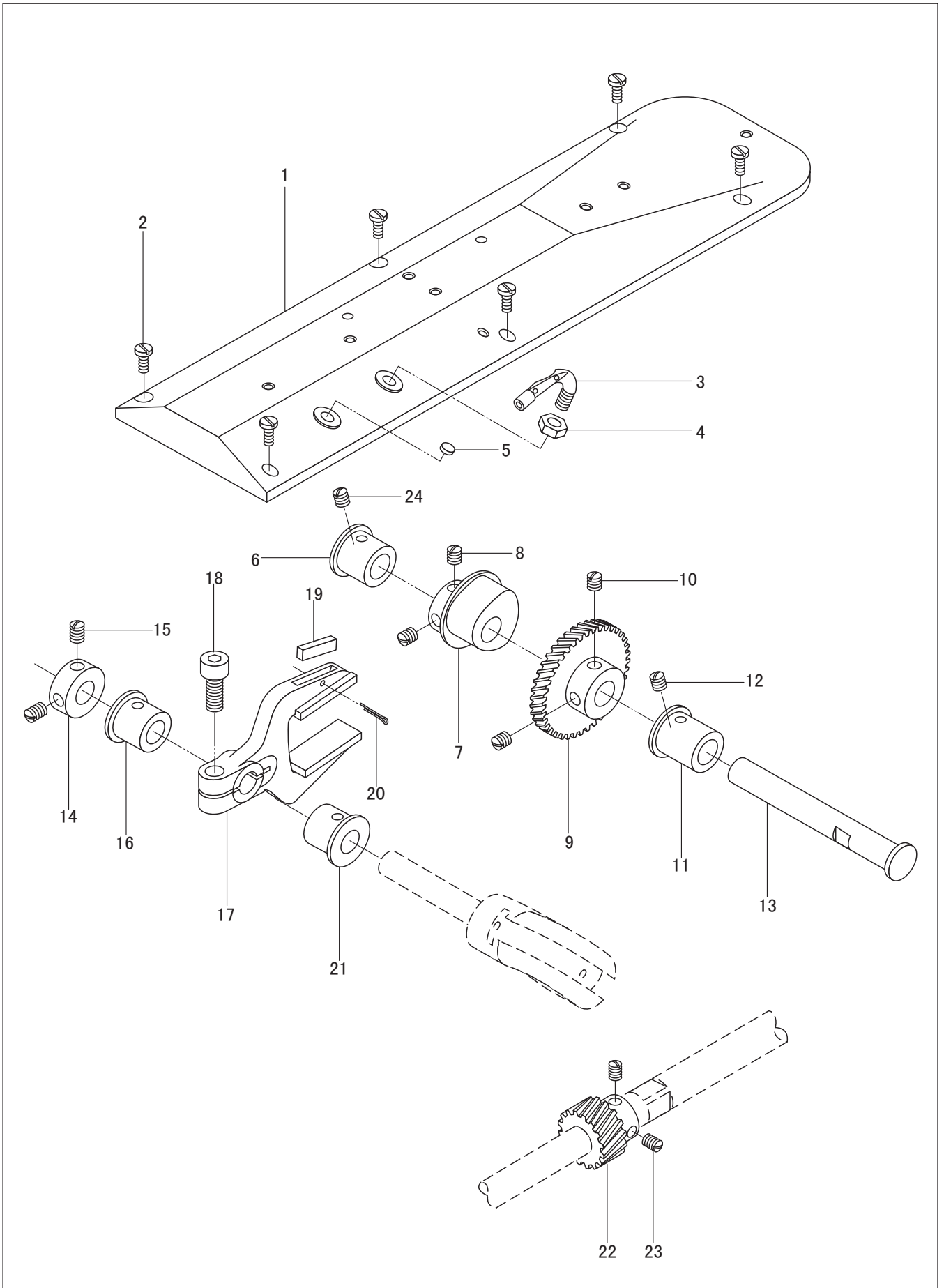

10.Zigzag gear and upper cover mechanism(-6BR)

No.	Parts No.	Name of parts	Qty.			Remarks
			6BR	6BR-3	6BR-4	
1	23KT1-002	Upper cover	1			
2	49WF2-012	Screw	6	6	6	
3	13WF2-066	Thread guide	1	1	1	
4	13WF2-067	Nut	1	1	1	
5	17KT1-029	Rubber plug	1	1	1	
6	23KT2-004	Zigzag shaft bushing(back)	1			SM9/64" 4 0
7	22KT2-001	Zigzag eccentric	1			
8	16WF1-053	Screw	2	2	2	
9	23KT2-002	Zigzag gear(big)	1			
10	7KT3-033	screw	2	2	2	
11	17KT4-029	Zigzag shaft bushing (front)	1			
12	6K1-065	screw	1	1	1	SM1/4" 32
13	17KT4-027	Zigzag shaft	1	1	1	
14	17KT4-028	Collar	1	1	1	SM1/4" 40
15	16WF1-053	Screw	1	1	1	
16	17KT4-029	Bushing (back)	1	1	1	SM15/64" 2 8
17	23KT2-005	Zigzag eccentric fork	1			
18	17KT4-031	Screw	1	1	1	
19		Oil felt	1			SM1/4" 32
20		Cotter ring	1			
21	17KT4-029	Bushing (front)	1	1	1	
22	23KT2-003	Zigzag gear (small)	1			M8 1 . 25
23	21WF1-043	Screw	2	2	2	
24	13WF6-018	Screw	1	1	1	GB/T91 1 1 4 镀镍
						SM11/64" 4 0

11. Accessories

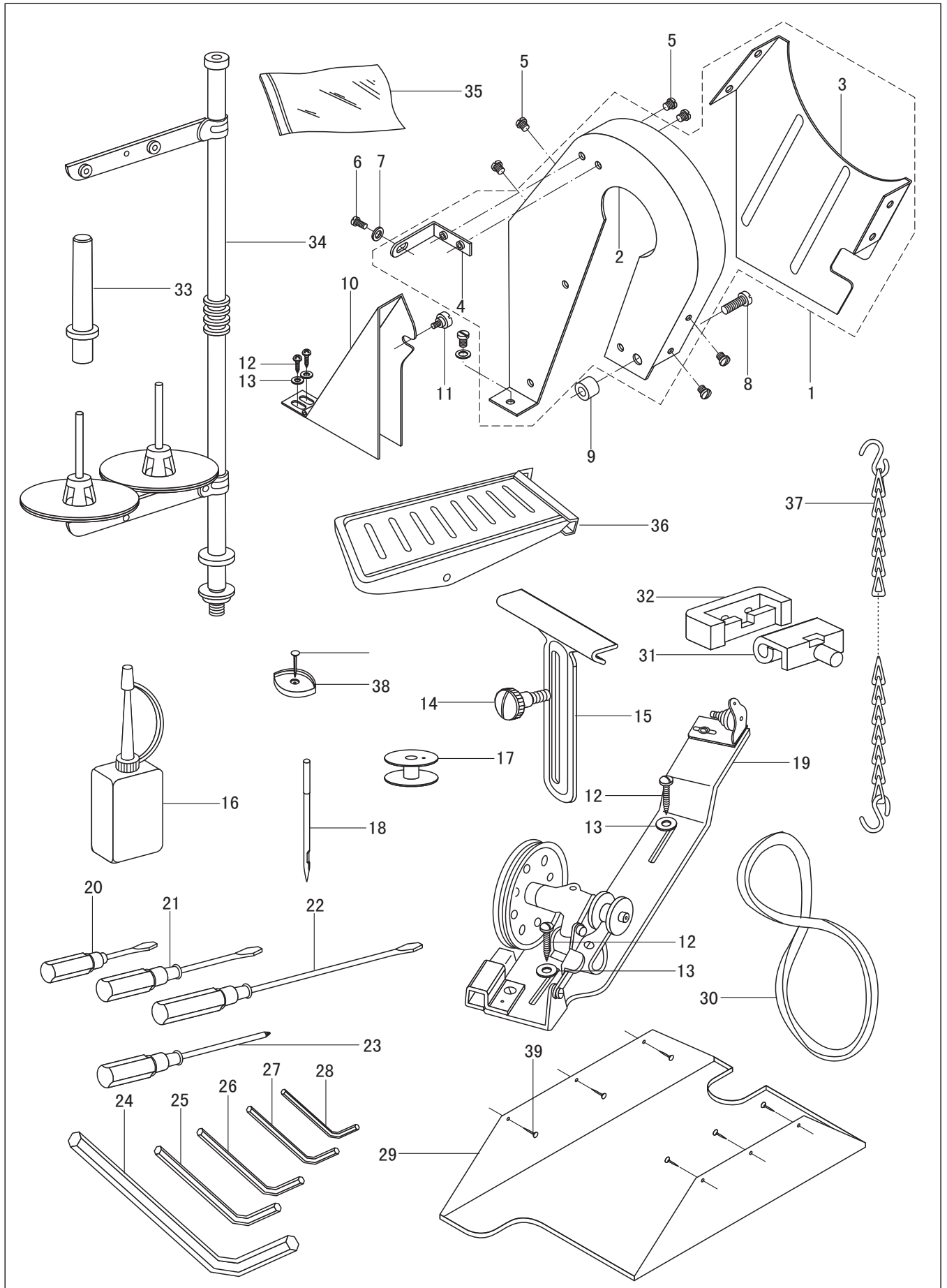

11. Accessories

No.	Parts No.	Name of parts	Qty.			Remarks
			6BR	6BR-3	6BR-4	
1		Belt guard complete	1	1	1	
2	17KT7-006	Belt guard (inside)	1	1	1	
3	17KT7-007	Belt guard (outside)	1	1	1	
4	17KT7-010	Bracket	1	1	1	
5	6K6-005	Screw	6	6	6	
6	6K4-033	Screw	2	2	2	
7		Washer	2	2	2	
8	17KT7-012	Screw	1	1	1	
9	17KT7-009	Roller	1	1	1	SM1/8" 4 4
10	17KT7-008	Belt guard(small)	1	1	1	SM3/16" 28
11	17KT7-011	Screw	1	1	1	GB/T848 6 镀镍
12		Screw	4	4	4	M6 1
13		Washer	4	4	4	
14	6K4-030	Screw	1	1	1	
15	6K6-007	Edge guide	1	1	1	SM1/8" 4 4
16	33TF-011	Oil pot	1	1	1	GB/T5282 ST4.8 1 9
17	6K6-008	Bobbin	6	6	6	GB/T97.1 5 镀镍
18	17KT4-034	Needle	6	6	6	SM9/64" 40
19	6K6-009	Bobbin Winder assembly	1	1	1	
20	33TF-014	Screwdriver(Small)	1	1	1	
21	33TF-013	Screwdriver(middle)	1	1	1	
22	33TF-012	Screwdriver(big)	1	1	1	
23	35WF6-002	Screwdriver(middle)	1	1	1	DDXH14 25#
24		Hexagonal wrench	1	1	1	
25	13F-010	Hexagonal wrench	1	1	1	
26	1F-011	Hexagonal wrench	1	1	1	
27	1F-010	Hexagonal wrench	1	1	1	
28	91WF6-006	Hexagonal wrench	1	1	1	S=6mm
29	17KT7-002	Oil pan	1	1	1	S=4mm
30		V-belt	1	1	1	S=3mm
31	22T9-007F1	Machine hinge	2	2	2	S=2.5mm
32	22T9-007F2	Hinge cushion	2	2	2	S=1.5mm 1
33		Machine support rod	1	1	1	
34	4F-007	Stand complete	1	1	1	M50
35		Parts bag	1	1	1	
36		Pedal complete	1	1	1	
37		S-type hook with chain	1	1	1	
38	6K6-006	Rubber cushion	4	4	4	
39		Screw	10	10	10	长1000mm 长22mm

TW7-6B

EXTRA HEAVY-DUTY ZIG ZAG LOCKSTITCH SEWING MACHINE
EXTRA SCHWERE ZICK-ZACK-DOPPELSTIPPSTICH-NÄHMASCHINE



This machine may only be operated by adequately trained operators only after having completely read and understood the instruction manual.

Parts are subject to changes in design without prior notice.



Certificate of the international ISO9001



Certificate of the ISO14001



Certificate of the international CE



Certificate for Ecolabeling Product



Certificate for Energy Conservation Product

XI'AN TYPICAL INDUSTRIES CO., LTD.

No. 335, South Taibai Road
Xi'an 710068, P.R.China
Tel.: +86-29-88279093 // 88279150 // 88279151
Fax: +86-29-88249715 // 88245215

E-mail: tic@chinatypical.com
www.chinatypical.com

XI'AN TYPICAL EUROPE GmbH

Hertelsbrunnenring 9
D-67657 Kaiserslautern
Tel.: +49 (0)631 316019-0
Fax: +49 (0)631 316019-11

E-mail: sales@typical-europe.com
www.typical-europe.com