

TW3-441

INSTRUCTION BOOK // PARTS CATALOGUE



EXTRA HEAVY-DUTY COMPOUND FEED
CYLINDER ARM LOCKSTITCH SEWING MACHINE



TYPICAL

CONTENTS

Operation Instruction

1.Brief introduction.....	1
2.Main specifications.....	1
3.Operation preparation.....	1
4.Installing the motor.....	1
5.Installing the belt guard.....	2
6.Lubrication.....	2
7.Installing the needle.....	2
8.Choosing thread.....	3
9.Winding bobbin thread.....	3
10.Installing and uninstalling the bobbin.....	3
11.Threading needle thread.....	4
12.Adjusting thread tension.....	4
13.Adjusting stitch length.....	4
14.Adjusting thread take-up spring.....	5
15.Adjusting the pressure of presser foot.....	5
16.Adjusting the height of feed dog.....	5
17.The relationship between needle and shuttle.....	6
18.Adjusting the lifting amount of alternating foot.....	6
19.Adjusting the timing of upper feed.....	6

Parts Manual

1.Machine casting components.....	7-8
2.Upper shaft components.....	9-10
3.Needle bar and upper feed components (TW3-441)	11-12
4.Needle bar and upper feed components (TW3-471)	13-14
5.Presser foot lifting components.....	15-26
6.Presser bar components.....	17-18
7.Stitch length adjusting components.....	19-20
8.Lower shaft driving components.....	21-22
9.Threading components.....	23-24
10.Bobbin thread winding components.....	25-26
11.Lifting components.....	27-28
12.Accessories.....	29-30

Operation Instruction

1. Brief introduction

This series machines are widely used in the industry of bags, tents, mat, etc.

These machines adopt linking lever to take up thread, single needle and special oscillating shuttle to form lock-stitch seam. TW3-471 is top and bottom feed and TW3-441 is compound feed, they have strong feeding power and can easy stitch several plies, slippery, extra thick or extra long materials. The stitch seam is neat and beautiful.

These products are suitable for sewing leather belt, tents, sails, construction barrier, industrial bags, etc.

2. Main specifications

Applications	Heavy and Extra-heavy weight materials
Max. sewing speed	800s.p.m
Max. stitch length	11mm
Needle bar stroke	56mm
Presser foot lift height	13mm by hand 20mm by pedal
Hook	KSP-204N
Needle	DY×17 26#
Cylinder diameter	81mm
Lubrication	Oiled by hand
Motor power	550W

3. Machine installation

1. Clearing the machine

Before the head is packed, all of the parts of the machine are coated with anti-rust grease, meanwhile the grease can harden and the dust can cover the machine surface during long time storage and shipment, so, the dust and grease must be cleared by clean cloth with gasoline.

2. Examination

Although every machine is conformed by strict inspection and test before delivery, the parts of the machine may be loose and deformed after long distance transportation with jolt. A thorough examination must be performed. Turn the balance wheel slightly by hand to check if there is running obstruction, parts collision, uneven resistance and abnormal noise. If any of these exist, adjustment must be made accordingly before running.

4. Installing the motor (Fig. 1)

Move the motor C leftward or rightward to make the hand wheel belt groove A and motor pulley belt groove B run in line.

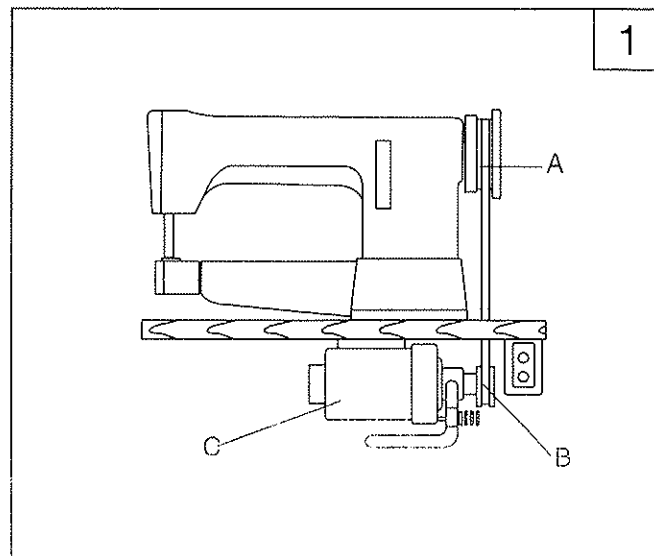

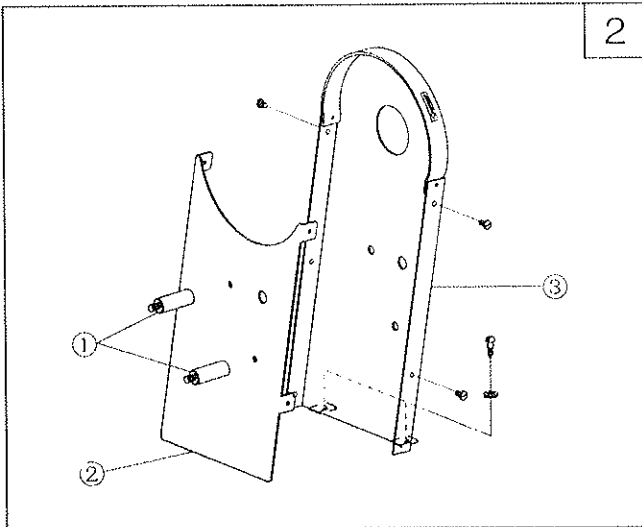

5. Installing the belt guard (Fig. 2)

- Please install the belt guard for the safety purpose
- Install the pin supporter ① into the screw hole on the machine casting;
 - Install the guard ② on the casting;
 - Put the V-belt on the hand wheel;
 - Install the guard ③ on the guard ②;
 - Fix the guard on the table with wooden screw.

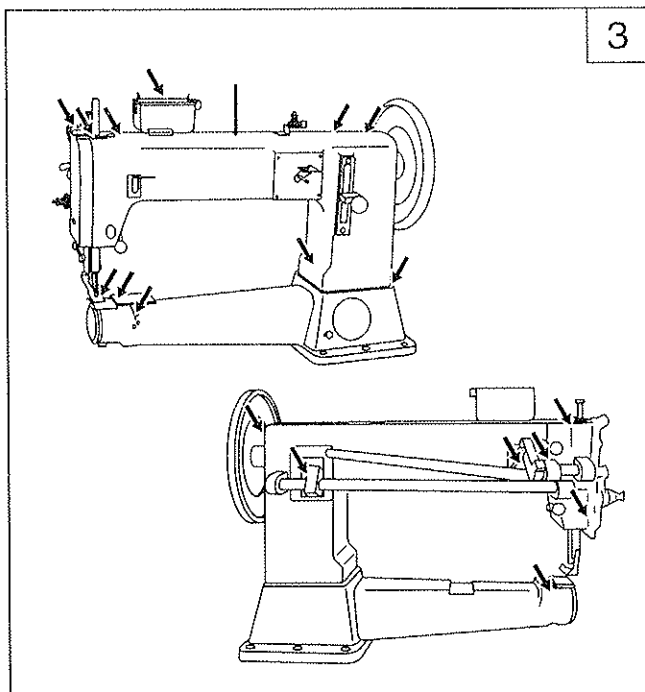

6. Lubrication (Fig. 3)

Please add the oil at the places shown by arrows.

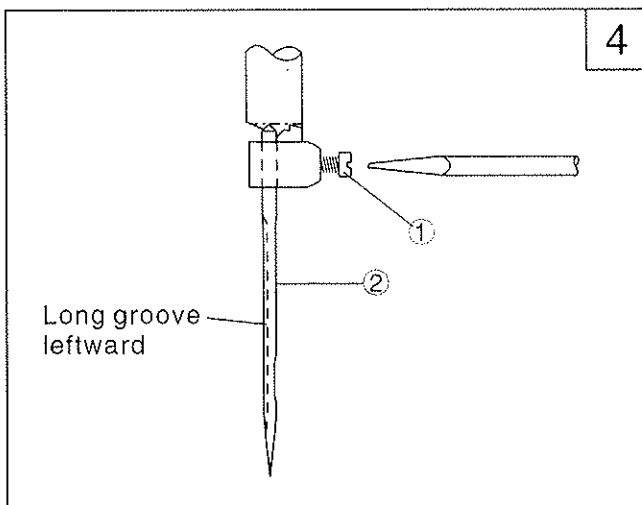

7. Installing the needle (Fig. 4)

- Turn the hand wheel to lift the needle bar at its highest position;
- Loosen the screw ① and keep the long groove A of needle ② rightward;
- Fully insert the needle shank up to the bottom of needle bar;
- Tighten the screw ①.

8.Choosing thread (Fig. 5)

The needle thread should be left-twist; the bobbin thread may be left-twist or right-twist. The way judging the thread twist: hold the thread by left hand, twist it by right hand as the direction shown in the Fig.5,if the thread changes tightly, it's left-twist, on the contrary, it's right-twist.

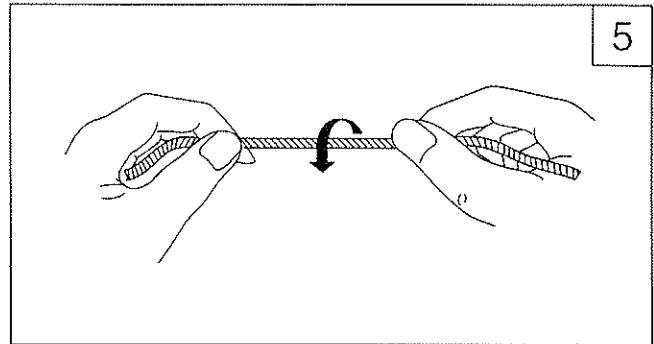

9.Winding the bobbin thread (Fig. 6)

a. Threading the thread from thread spool and pass through A, B, C, D, then wind thread several corcles around bobbin;

b. Put the winding lever onto bobbin, the winding pulley will press the friction pulley in the arm;

c. Thread amount can be adjusted by screw ②, the optimum capacity of bobbin thread is fill about 80% of bobbin outside diameter, turn the screw clockwise to increase the amount, on the contrary, decrease the amount.

d. After finish, loosen the winding lever and thread winder will stop automatically.

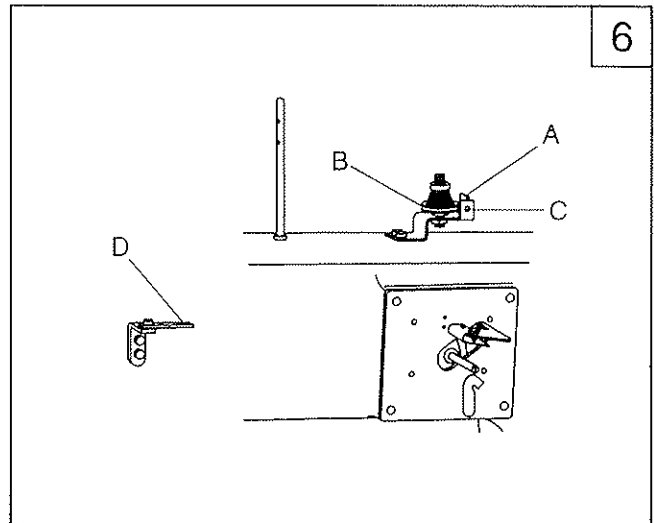

10.Installing and uninstalling the bobbin (Fig.7)

1. Uninstalling the bobbin

Open the shuttle cover and lower the needle bar at its lowest position, insert the opener ③ between spring ① and bobbin case ②, press the spring ① down and draw the bobbin case ② out, the bobbin will be pulled out from bobbin case.

2. Installing the bobbin

When install the bobbin, draw the thread tip out and put the bobbin ④ into bobbin case ⑤, thread the bobbin thread from slit ⑦, then pass it through the hole under the tension spring ⑥.

The bobbin case will be locked by spring ① after being put into shuttle.

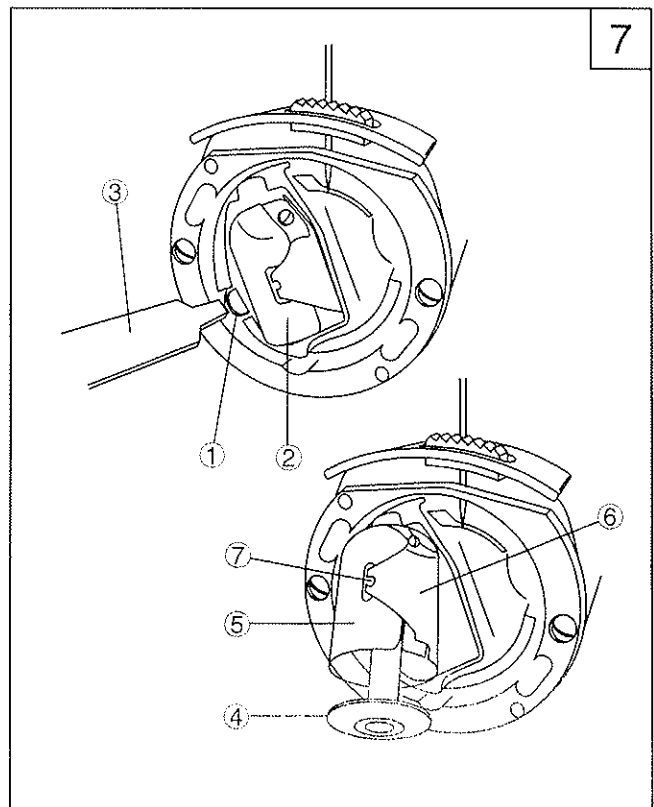

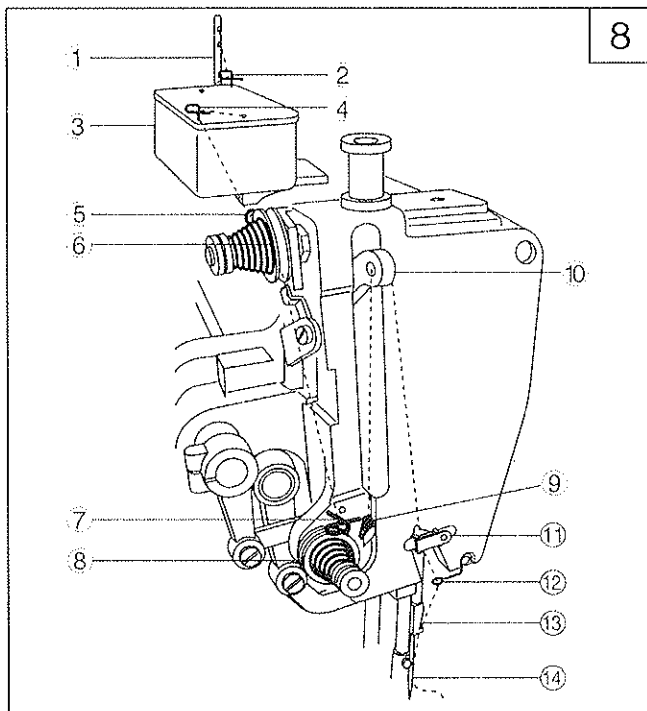

11. Threading needle thread (Fig. 8)

The sequence of threading is shown in the Fig 8 from (1)~(14).

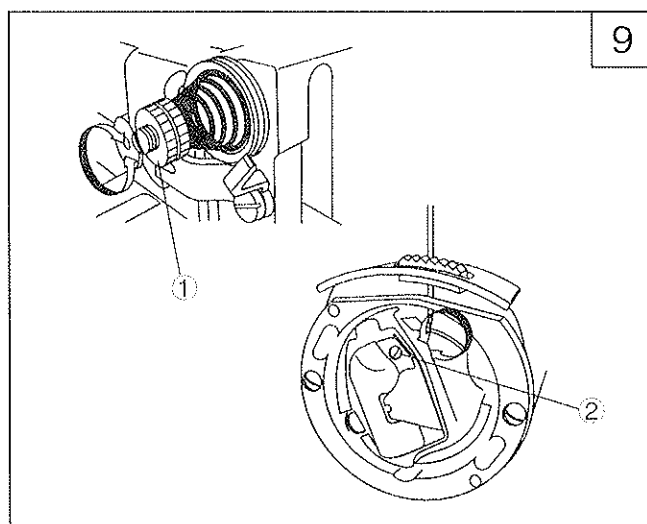

12. Adjusting thread tension (Fig. 9)

1. Adjusting needle thread tension.

Turn the nut ① clockwise to increase the needle thread tension, turn the nut counter-clockwise to decrease the needle thread tension.

2. Adjusting bobbin thread tension

Turn the screw ② clockwise to increase the bobbin thread tension; turn the screw counter-clockwise to decrease the tension.

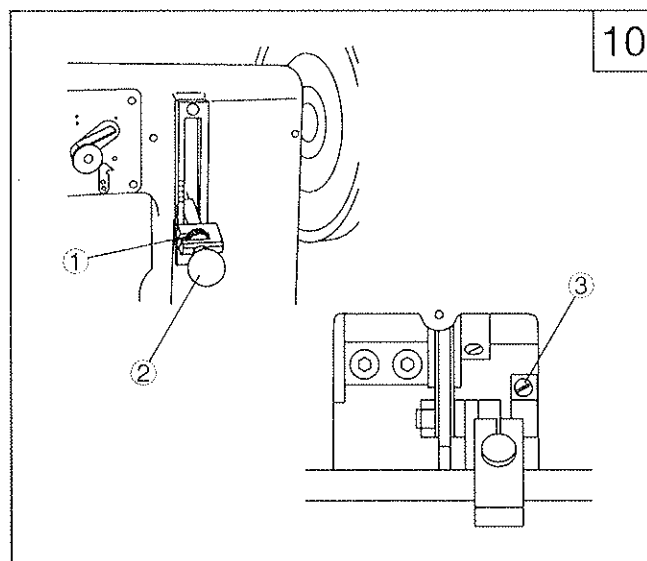

13. Adjusting stitch length (Fig. 10)

Turn the stitch length adjusting nut ① clockwise or counter-clockwise, the numbers on graduation board shown the sizes of the stitch length, if the stitch length confirmed, please tighten the nut ②.

For reverse feed, lift the stitch length adjusting screw bar to perform reverse sewing, release the screw bar, the forward sewing is resumed.

Note: if the screw bar becomes loose because of moving upward or downward for a long time, please turn the screw ③ to maintain the proper tension.

14. Adjusting thread take-up spring (Fig.11)

1. Changing the stroke of thread take-up spring

a. Loosen the screw ① and move the stop plate ② upward and downward;

b. Move the stop plate downward to increase the stroke of thread take-up; move the plate upward to decrease the stroke of thread take-up.

2. Adjusting the tension of thread take-up

Loosen the nut ③, turn the spring shaft counter-clockwise to increase the tension of thread take-up; turn the shaft clockwise to decrease the tension. Please use a screw driver to insert the split on the spring shaft and turn the spring shaft to get the required tension.

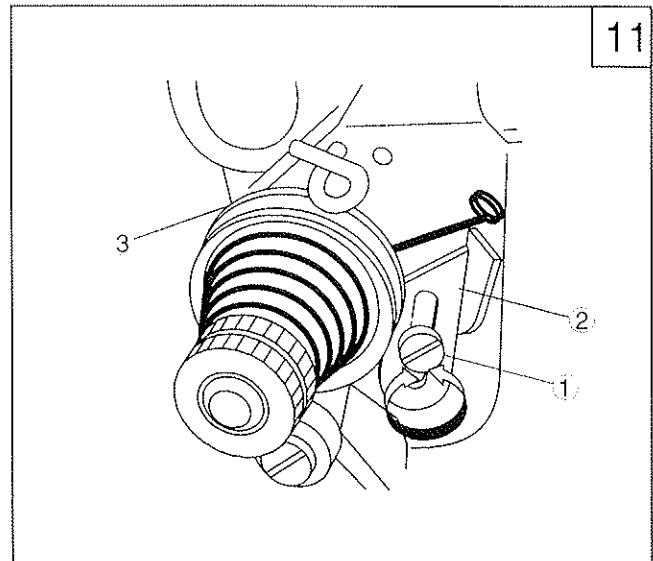

15. Adjusting the pressure of presser foot (Fig.12)

The proper pressure of presser foot should be adjusted according to the materials to be sewn.

a. Turn the screw ① clockwise to increase the pressure, on the contrary, decrease the pressure.

b. After finish, tighten the nut ②.

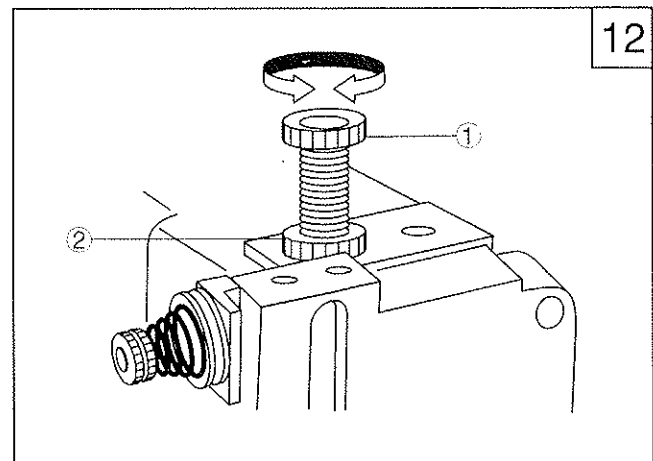

16. Adjusting the height of feed dog (Fig.13)

The adjustment position of feed dog is higher 1.3~1.5 mm than needle plate, please adjust it as following sequence according to sewing requirements or after changing a new one:

a. Confirm the highest position of feed dog, then tighten the feed dog screw ①;

b. Temporarily adjust the height of feed dog higher or lower compare to the standard height according to special sewing situation.

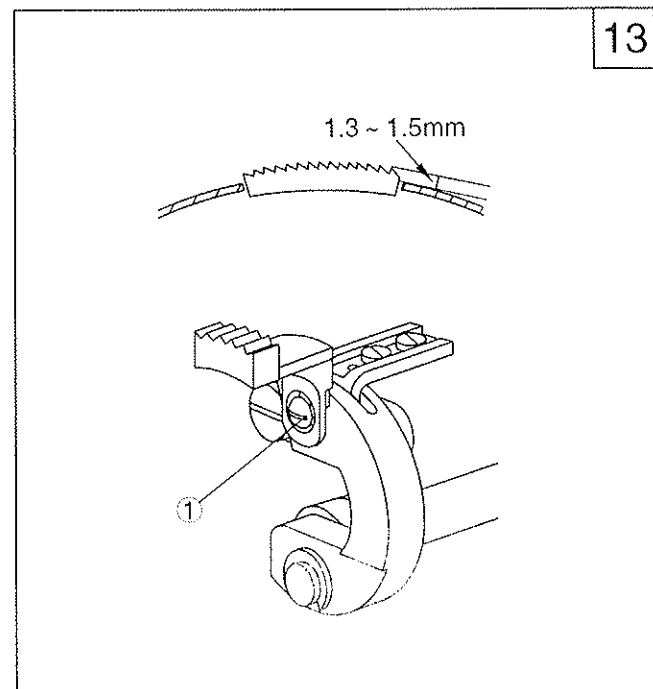

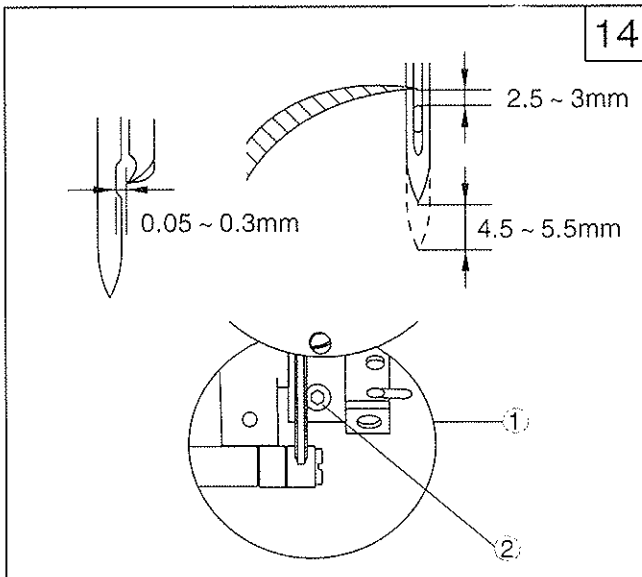

17. The relationship between needle and shuttle (Fig.14)

a. confirm the height of needle bar

When the needle bar is lifted 4.5~5.5mm from its lowest position, the tip of shuttle should locate at the center of needle bar and the clearance between the top of needle bar hole and the tip of shuttle is 2.5~3mm.

b. Confirm the position of shuttle

Loosen the crank screw ② in the bed hole ①, move the crank forward or backward, after adjust the position of the tip of shuttle, tighten the screw ②.

c. The flank clearance between the tip of shuttle and needle bar should be 0.05~3mm, loosen the rear crank screw and collar screw of lower shaft, move the lower shaft leftward or rightward, after adjustment, tighten the screws.

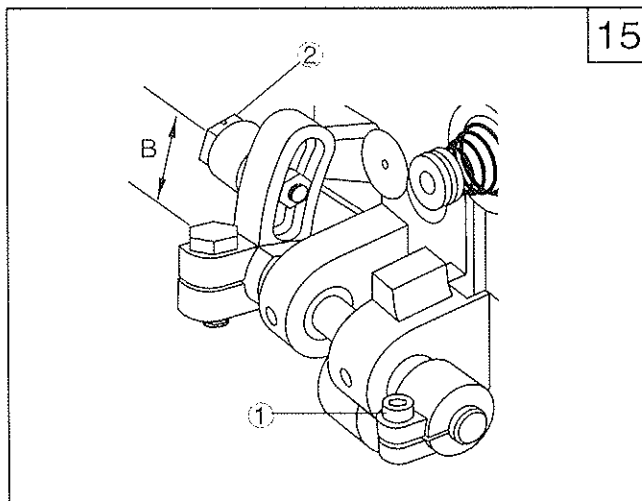

18. Adjusting the lifting amount of alternating foot (Fig. 15)

The lifting amount of alternating foot can be adjusted within a certain range, for normal sewing, the lifting amount of outer presser foot is 6mm, the lifting amount of inner presser foot is 4.5mm, if the other mechanism is fix, the lifting amount of two feet is constant.

Adjusting method: loosen the crank screw ①, turn the crank upward shown in the Fig 15 to increase the lifting amount of outer presser foot, on the contrary, decrease the amount, after finish, tighten the screw. Adjusting method of lifting amount of two feet: loosen the screw ②, adjust the central distance B between the screw and upper feed shaft, shorten the distance B will increase the lifting amount, on the contrary, decrease the amount. Please note the range of adjustment is limited, please don't be overlarge.

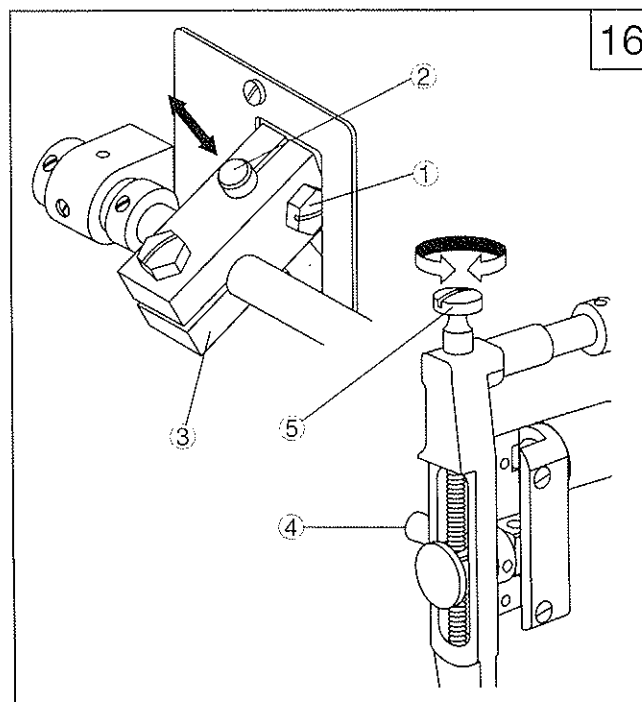

19. Adjusting the timing of upper feed (Fig.16)

a. Ignoring lower feed, lower the presser foot lifting bar and the coarse stitch of upper feed is realized.

b. For TW3-441, loosen the screw ①, adjust the relative position between ② and ③, after finish, tighten the screw ①.

c. For TW3-471, loosen the screw ④, turn the worm ⑤ as the direction shown in the Fig.16, after finish, tighten the screw ④.

Parts Manual

1. Machine casting components

NO	Parts No	Name of parts	Qty.	Remarks
1	52WF2-001	Casting	1	For TW3-471
	58WF2-001	Casting	1	For TW3-441
2	52WF2-002	Cylinder bed	1	
3		Washer	2	GB95-85-4
4	19WF4-002	Screw	3	
5	52WF2-005	Cylinder cover	2	
6	52WF2-006	Needle plate	1	For TW3-471
	58WF2-004	Needle plate	1	For TW3-441
7	52WF2-007	Screw	2	
8	52WF2-008	Plate	1	
9	21WF4-055	Screw	2	
10	52WF2-003	Face plate	1	For TW3-471
	58WF2-002	Face plate	1	For TW3-441
11	16WF3-061	Screw	2	
12	22T1-003C4	Rubber plug	1	For TW3-441
13	52WF2-009	Oil pipe	3	
14	52WF2-004	Back cover	1	For TW3-471
	58WF2-003	Back cover	1	For TW3-441
15	16WF2-053	Brand label	1	
16	1KT1-005	Caution label	1	
17	52WF2-055	Model label	1	For TW3-471
	58WF2-005	Model label	1	For TW3-441
18		Rivet	4	Standard parts
19	4KT1-005	Serial label	1	
20	35WF1-054	Rivet	2	

2.Upper shaft components

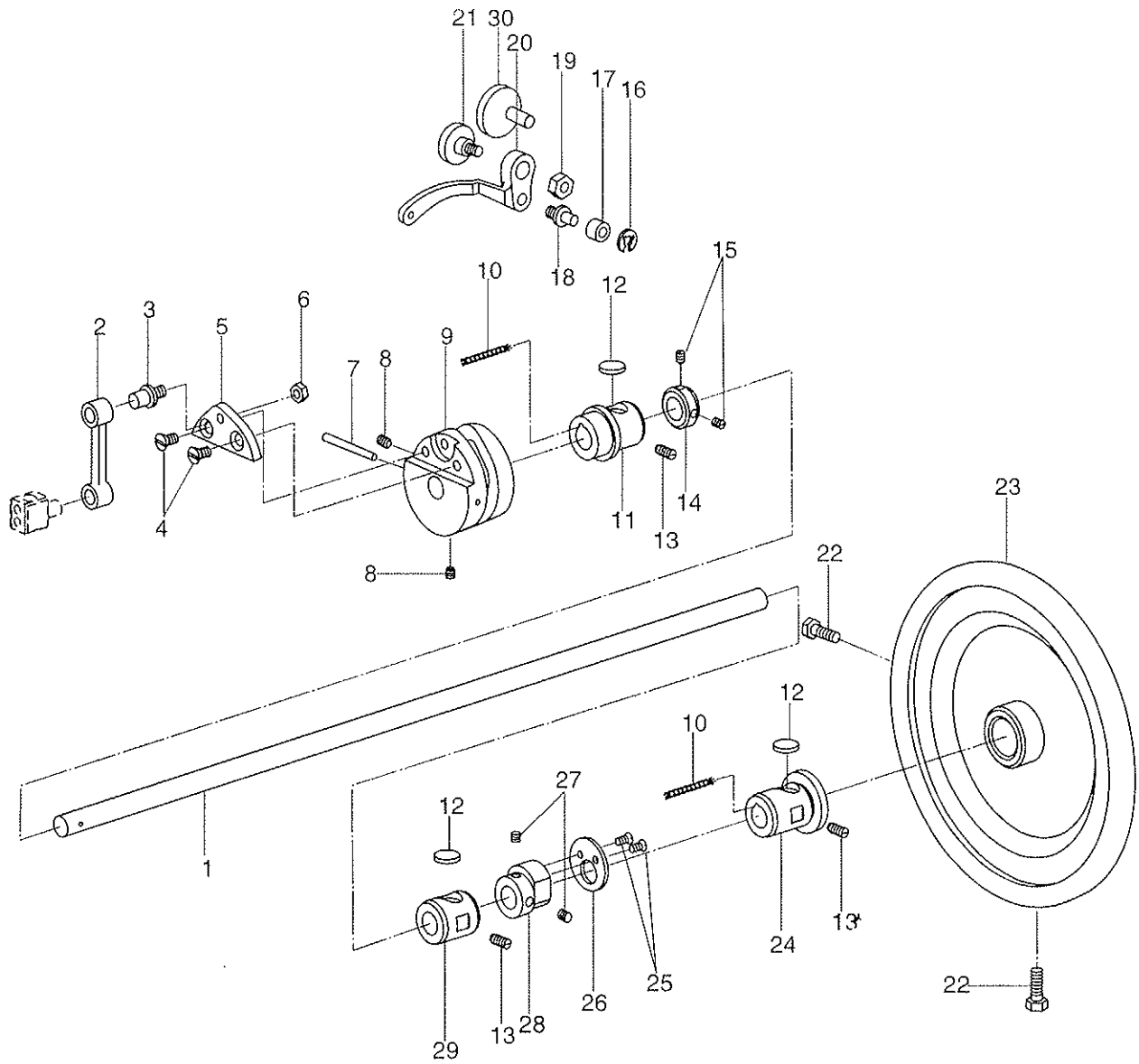

2.Upper shaft components

NO	Parts No	Name of parts	Qty.	Remarks
1	52WF1-001	Upper shaft	1	
2	52WF1-007	Needle bar link	1	M5 × 8 GB78-85
	58WF1-001	Needle bar link	1	
3	52WF1-010	Pin	1	M4 × 4 GB74-85
4	52WF1-009	Screw	2	
5	52WF1-008	Needle bar link base	1	
6	7KT1-007	Nut	1	
7	7KT1-052	Pin	1	M5 × 6 GB77-85
8	21WF1-022	Screw	2	
9	52WF1-005	Thread take-up cam	1	
10		Oil wick	2	
11	52WF1-002	Bushing (front)	1	
12		Oil felt	3	
13	JO.0.40	Screw	3	SM15/64" × 28 × 8
14	52WF1-041	Collar	1	
15	22WF4-002	Screw	2	
16		Retaining ring	1	GB960-86-5
17	52WF1-013	Rolling ball	1	
18	52WF1-014	Thread take-up pin	1	
19	7KT1-007	Nut	1	
20	52WF1-011	Thread take-up lever	1	M5 × 6 GB68-85
21	52WF1-012	Screw	1	
22	7KT1-014	Screw	2	
23	52WF1-006	Balance wheel	1	
24	52WF1-004	Bushing (rear)	1	
25	7KT4-035	Screw	2	
26	52WF4-028	Stopping plate	1	M6 × 0.75
27	21WF3-010	Screw	2	
28	52WF4-027	Feed cam	1	
29	52WF1-003	Bushing (middle)	1	
30	52WF1-058	Pin	1	

3. Needle bar and upper feed components (TW3-441)

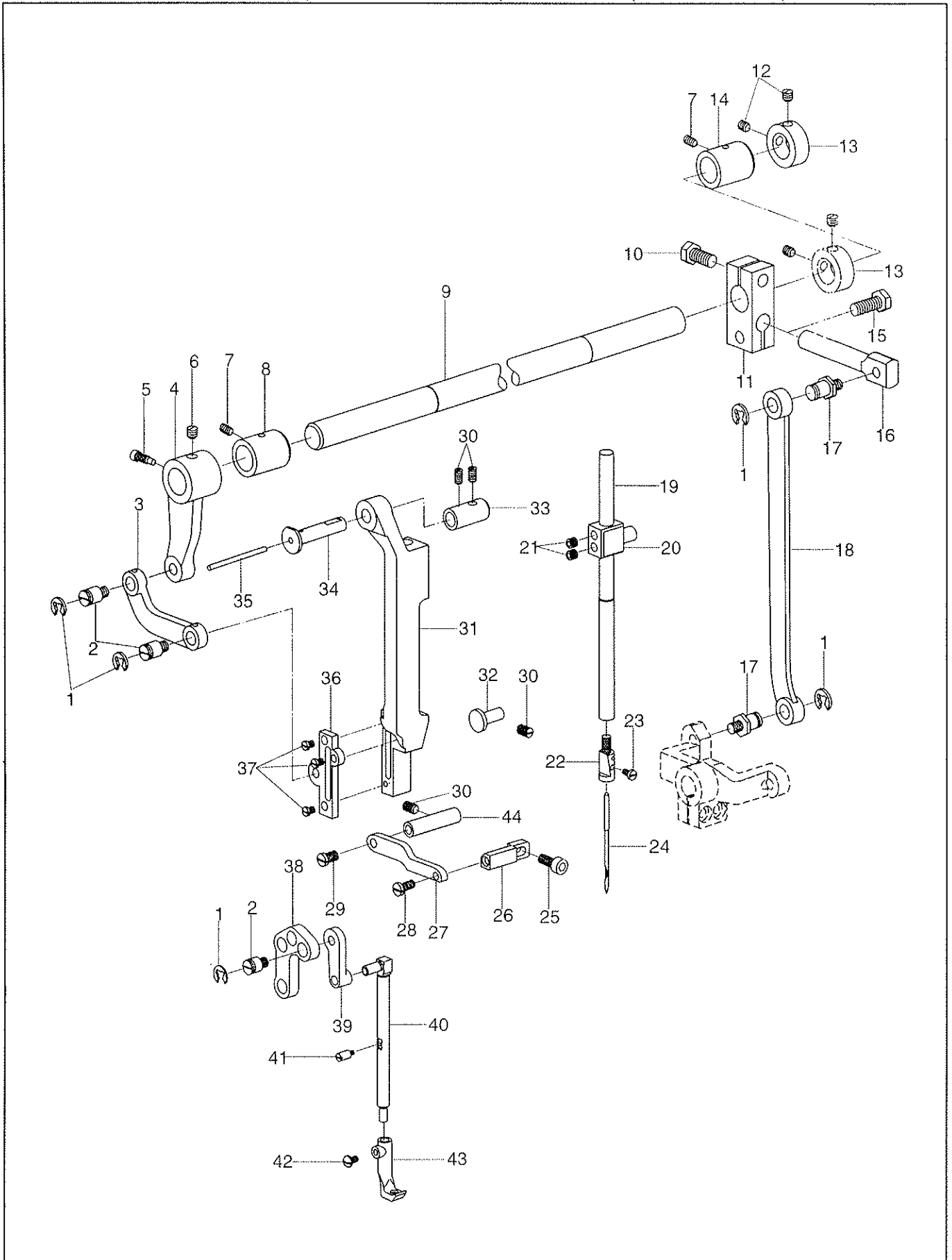

3. Needle bar and upper feed components (TW3-441)

NO	Parts No	Name of parts	Qty.	Remarks
1		Lock ring	5	GB896-86-8
2	52WF5-014	Connecting pin	3	
3	58WF5-007	Crank link (front)	1	
4	58WF5-006	Front crank	1	
5	61-04-01/B2	Screw	1	
6	22WF4-002	Screw	1	
7	17T5-016	Screw	2	
8	58WF5-003	Bushing (front)	1	
9	58WF5-001	Presser foot rocking shaft	1	
10	58WF5-009	Screw	1	
11	58WF5-008	Crank	1	
12	22WF4-002	Screw	4	
13	58WF5-002	Collar	2	
14	58WF5-004	Needle bar rocking shaft bushing (rear)	1	
15	58WF5-011	Screw	1	
16	58WF5-010	Connecting pin	1	
17	52WF4-005	Connecting pin	2	
18	58WF5-005	Needle bar rocking link	1	
19	58WF1-002	Needle bar	1	
20	58WF1-004	Needle bar connector	1	
21	21WF3-012	Screw	2	
22	58WF1-003	Needle holder	1	
23	22T2-004	Screw	1	
24		Needle	1	DY × 3 26'
25	266024	Screw	1	
26	58WF5-024	Installing bracket	1	
27	58WF5-025	Pressing plate	1	
28	22T6-008D3	Screw	1	
29	37T2-210	Screw	1	
30	58WF5-015	Screw	4	
31	58WF5-012	Needle bar rocking frame	1	
32	58WF5-016	Pin	1	
33	58WF5-014	Pin bushing	1	
34	58WF5-013	Rocking frame shaft	1	
35		Oil wick	1	
36	58WF5-022	Guiding plate	1	
37	6A3-07	Screw	3	
38	58WF5-021	Swing board	1	
39	58WF5-020	Rocking link	1	
40	58WF5-018	Presser bar	1	
41	58WF5-019	Presser bar pin	1	
42	22WF4-014	Screw	1	
43	58WF5-017	Inner presser foot	1	
44	58WF5-023	Regulating pin	1	

4. Needle bar and upper feed components (TW3-471)

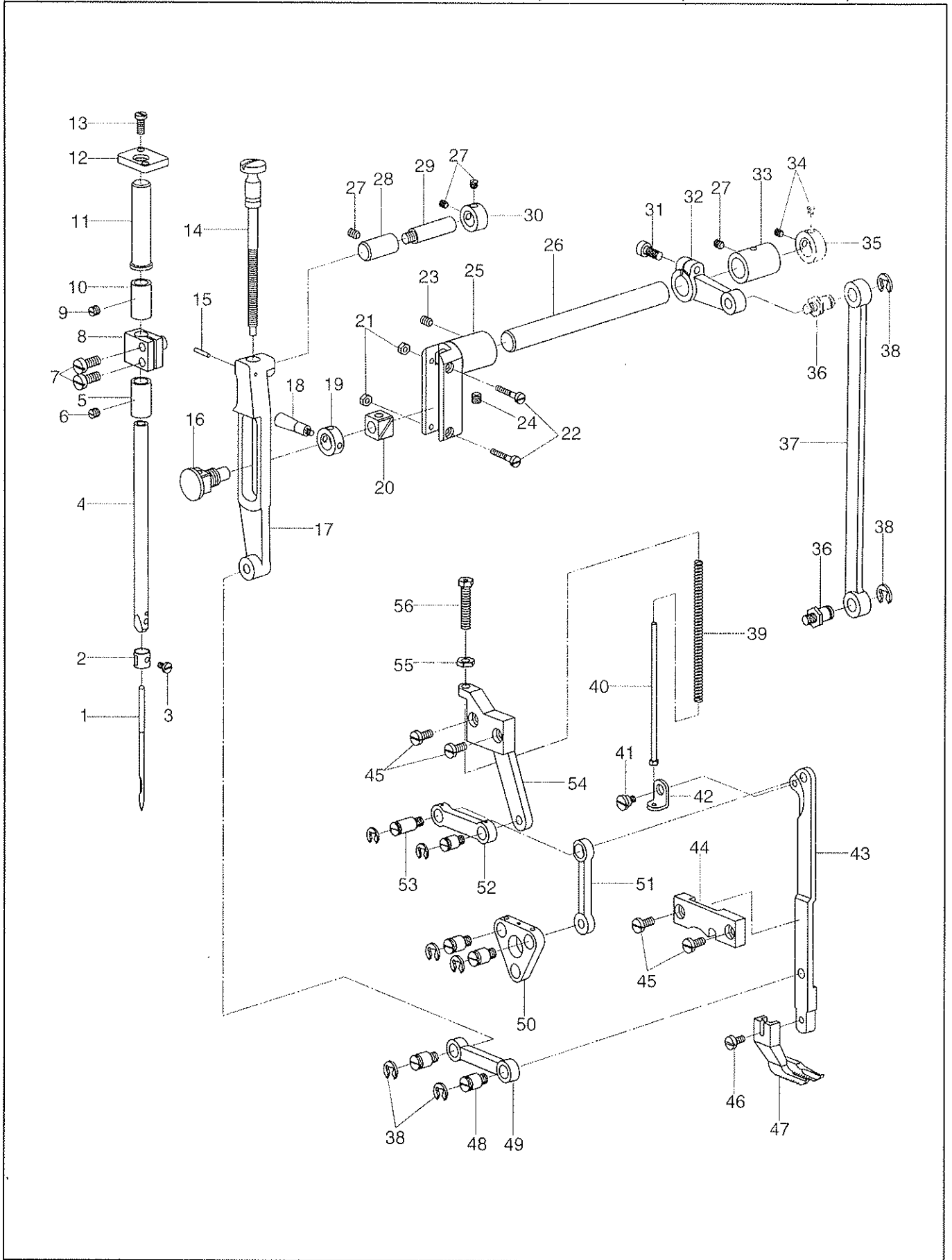

4. Needle bar and upper feed components (TW3-471)

NO	Parts No	Name of parts	Qty.	Remarks
1		Needle	1	DY × 3 26"
2	52WF1-019	Needle bar thread guide	1	
3	16WF2-020	Screw	1	
4	52WF2-015	Needle bar	1	
5	52WF1-017	Needle bar shaft (lower)	1	
6	52WF2-018	Screw	1	
7	22T3-007C2	Screw	2	
8	52WF1-020	Needle bar connector	1	
9	17T1-012	Screw	1	
10	52WF1-016	Needle bar bushing (upper)	1	
11	52WF1-021	Needle bar bushing	1	
12	52WF1-022	Needle bar bushing cover	1	
13	1WF5-039	Screw	2	
14	52WF5-024	Presser bar adjusting bar	1	
15		Pin	1	GB879-86-2.5 × 16
16	52WF5-027	Sliding block	1	
17	52WF5-025	Presser foot adjusting frame	1	
18	52WF5-029	Hand holder	1	
19	52WF5-030	Collar	1	
20	52WF5-021	Sliding block	1	
21	52WF5-023	Nut	2	
22	52WF5-022	Screw	2	
23	52WF5-020	Screw	1	
24	21WF1-020	Screw	1	
25	52WF5-019	Presser foot rocking bracket	1	
26	52WF5-015	Presser foot rocking shaft	1	
27	17T5-016	Screw	3	
28	52WF1-017	Pin bushing	1	
29	52WF5-026	Pin	1	
30	52WF5-030	Collar	1	
31	52WF5-003	Screw	1	
32	52WF5-016	Presser foot rocking crank	1	
33	52WF5-017	Bushing (rear)	1	
34	22WF4-002	Screw	2	
35	52WF1-041	Collar	1	
36	52WF4-005	Pin	2	
37	52WF5-018	Rocking link	2	
38		Lock spring ring	8	GB896-86-8
39	52WF5-035	Spring	1	
40	52WF5-036	Rod	1	
41	52WF5-038	Screw	1	
42	52WF5-037	Rod bareket	1	
43	52WF5-031	Walking foot connecting rod	1	
44	52WF5-034	Pressing plate	1	
45	37T2-210	Screw	4	
46	52WF5-033	Screw	1	
47	52WF5-032	Walking foot	1	
48	52WF5-014	Connecting pin	4	
49	52WF5-041	Rocking link	1	
50	52WF5-042	Triangular swing board	1	
51	52WF5-040	Presser foot lifting lever (2)	1	
52	52WF5-039	Presser foot lifting lever (1)	1	
53	52WF5-043	Long connecting pin	1	
54	52WF5-044	Bracket	1	
55	7KT1-007	Nut	1	
56	52WF5-045	Screw	1	

5. Presser foot lifting components

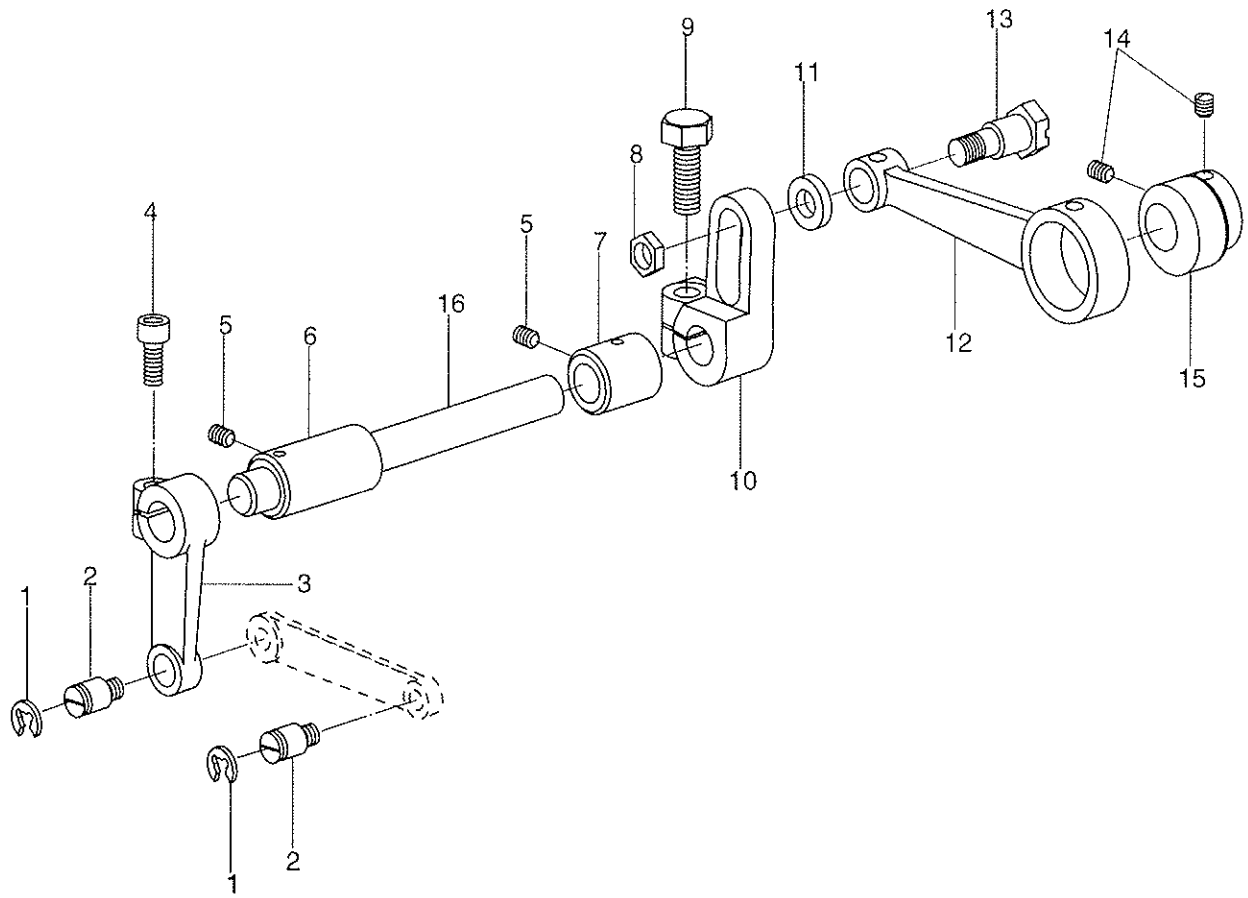

5.Presser foot lifting components

NO	Parts No	Name of parts	Qty.	Remarks
1		Lock spring ring	2	GB896-86-8
2	52WF5-014	Connecting pin	2	
3	52WF5-002	Lifting crank (front)	1	
4	52WF5-003	Screw	1	
5	17T5-016	Screw	2	
6	52WF5-005	Lifting shaft bushing	1	
7	52WF5-006	Lifting shaft bushing	1	
8	52WF5-011	Nut	1	
9	52WF5-008	Screw	1	
10	52WF5-007	Lifting adjsut crank	1	
11	52WF5-010	Washer	1	
12	52WF5-012	Lifting eccentric link	1	
13	52WF5-009	Screw	1	
14	22WF4-002	Screw	2	
15	52WF5-001	Lifting eccentric cam	1	
16	52WF5-004	Presser foot lifting shaft	1	

6. Presser bar components

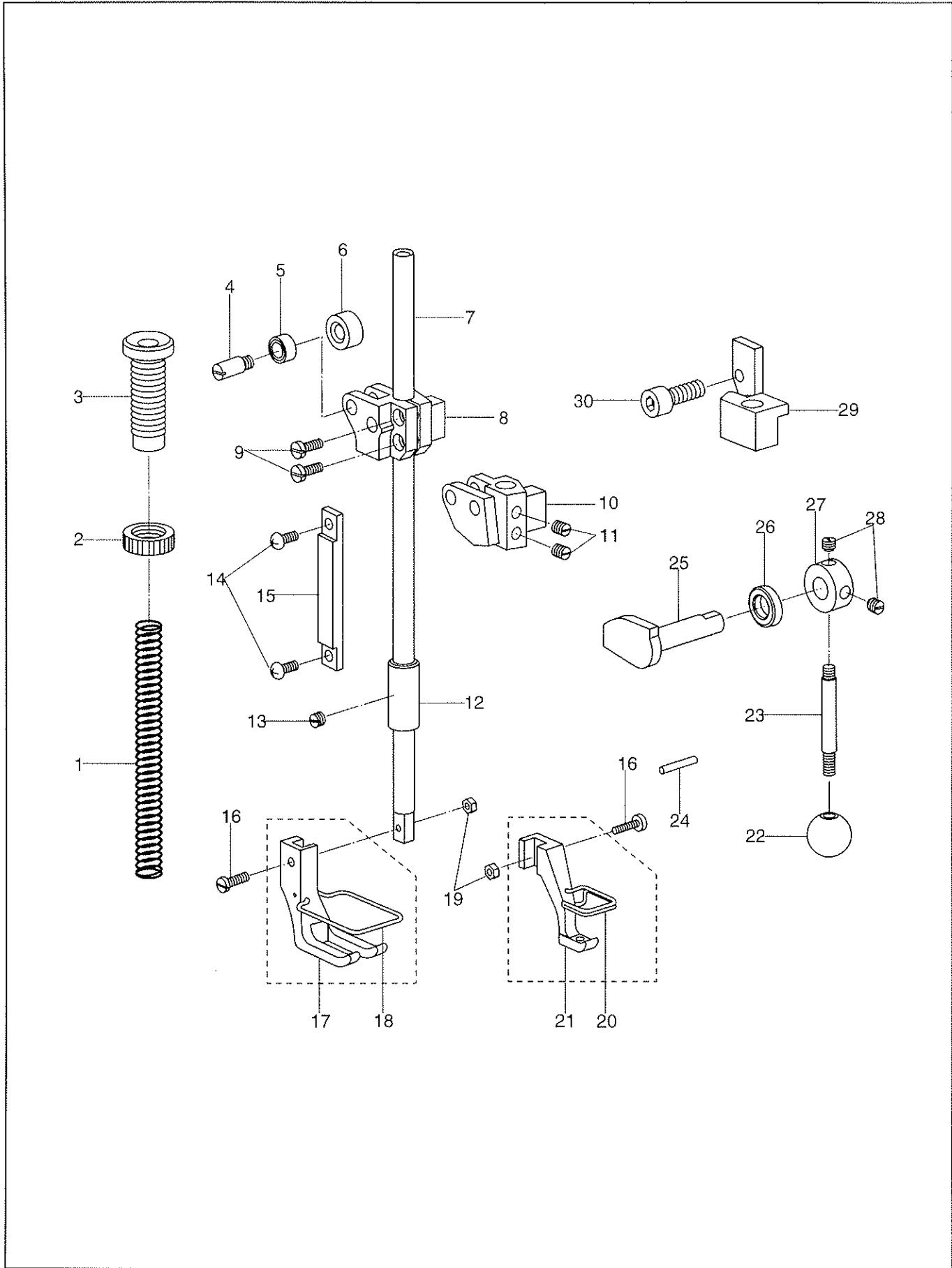

6.Presser bar components

NO	Parts No	Name of parts	Qty.	Remarks
1	52WF3-004	Pressure adjusting spring	1	
2	52WF3-006	Pressure adjusting nut	1	
3	52WF3-005	Pressure adjusting screw	1	
4	52WF3-014	Rolling column shaft	1	
5		Rolling column bearing	1	$\phi 10 \times \phi 7 \times 7.7$
6	52WF3-031	Bearing cover	1	
7	52WF3-001	Presser bar	1	
8	58WF3-003	Presser bar lifting bracket	1	For 441
9	1WF4-034	Screw	2	For 441
10	52WF3-013	Presser bar lifting bracket	1	For 471
11	6A6-08A	Screw	2	For 471
12	52WF3-002	Presser bar bushing	1	
13	52WF1-018	Screw	1	
14	22WF2-017	Screw	2	
15	52WF3-012	Guiding board	1	
16	52WF3-018	Nut	1	
17	58WF3-004	Outer presser foot	1	For 441
18	58WF3-001	Finger guard	1	For 441
19	52WF3-019	Nut	1	
20	52WF3-003	Finger guard	1	For 471
21	52WF3-017	Inner presser foot	1	For 471
22	52WF3-011	Presser bar lifting bar holder	1	
23	52WF3-009	Presser bar lifting bar shaft	1	
24		Retainer pin	1	GB879-86 3×20
25	52WF3-007	Lifting cam	1	
26	52WF3-008	Washer	1	
27	52WF3-010	Collar	1	
28	21WF1-043	Screw	2	
29	52WF3-015	Presser bar bracket	1	
30	52WF3-016	Screw	1	

7. Stitch length adjusting components

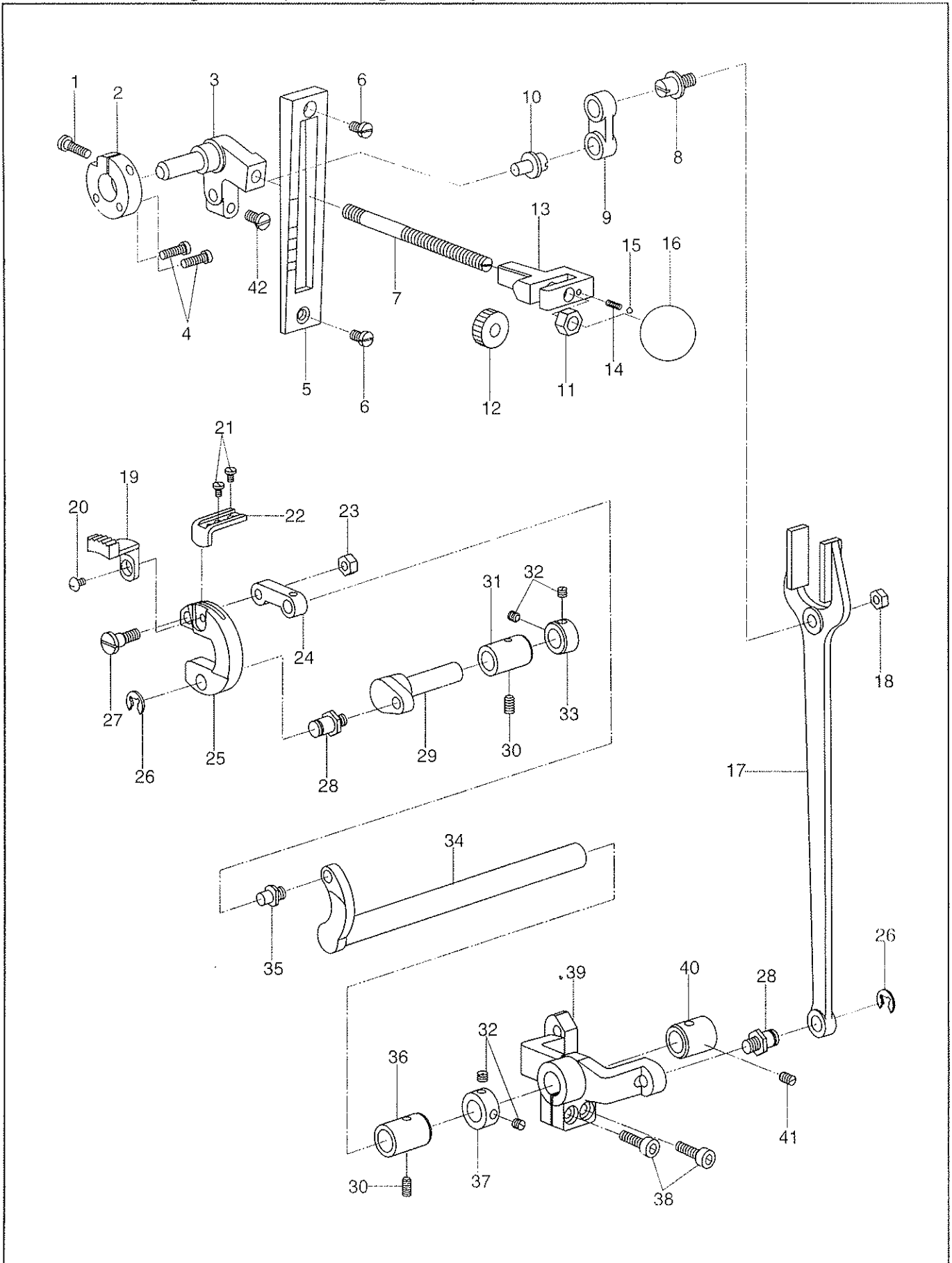

7. Stitch length adjust components

NO	Parts No	Name of parts	Qty.	Remarks
1	52WF4-020	Adjusting screw	1	
2	52WF4-019	Adjusting disc	1	
3	52WF4-018	Stitch length rocking bracket	1	
4	1WF4-034	Screw	2	
5	52WF4-022	Stitch length graduation plate	1	
6	7KT4-030	Screw	2	
7	52WF4-023	Screw bar	1	
8	52WF4-021	Pin screw	1	
9	52WF4-016	Link	1	
10	52WF4-029	Pin screw	1	
11	52WF4-025	Nut	1	
12	52WF4-024	Nut	1	
13	52WF4-026	Stitch length fixing base	1	
14	22WF4-030	Spring	1	
15		Steel ball	1	φ 3.7
16	7KT4-034	Hand holder	1	
17	52WF4-015	Feed fork	1	
18	7KT1-007	Nut	1	
19	58WF4-001	Feed dog	1	For 441
	52WF4-012	Feed dog	1	For 471
20	20T2-019	Screw	1	171031
21	40T2-202	Screw	2	
22	52WF4-013	Stopping plate	1	
23	7WF5-003	Nut	1	
24	52WF4-002	Link	1	
25	52WF4-001	Feed bed	1	
26		Lock spring ring	2	GB896-86-8
27	52WF4-003	Feed bed link	1	
28	52WF4-005	Connecting pin	2	
29	52WF4-004	Feed dog lifting crank shaft	1	
30	JO.O.40	Screw	2	16306
31	52WF4-006	Bushing	1	
32	22T3-002B2	Screw	4	191787
33	52WF4-007	Collar	1	
34	52WF4-008	Feed shaft	1	
35	52WF4-009	Pin	1	
36	52WF4-010	Feed shaft bushing (front)	1	
37	22T3-002B1	Collar	1	18306
38	7KT1-003	Screw	2	
39	52WF4-014	Feed crank	1	
40	52WF4-011	Feed shaft bushing (rear)	1	
41	01/B602	Screw	1	16003
42	49WF4-003	Screw	1	

8. Lower shaft driving components

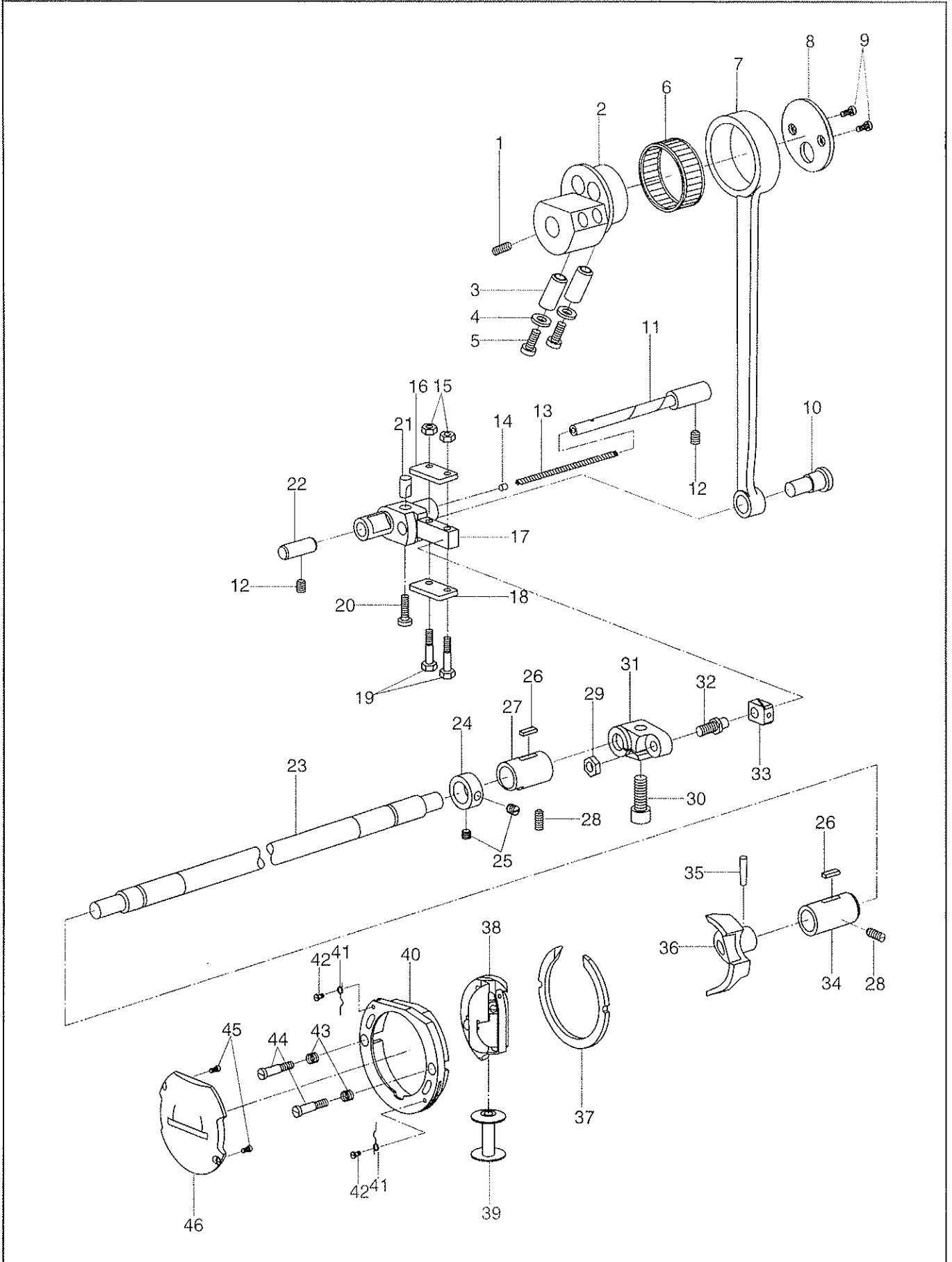

8. Lower shaft driving components

NO	Parts No	Name of parts	Qty.	Remarks
1	1WF4-010	Screw	1	
2	52WF1-048	Cam	1	
3	52WF1-049	Cam pin	2	
4	52WF1-051	Washer	2	
5	52WF1-050	Screw	2	
6		Needle bearing	1	$\phi 48 \times \phi 43 \times 17$
7	52WF1-052	Link	1	
8	52WF1-047	Eccentric disc	1	
9	49WF2-009	Screw	2	
10	52WF1-053	Connecting pin	1	
11	52WF1-043	Shaft	1	
12	01/B602	Screw	2	
13	22T1-013	Oil wick	1	
14	52WF1-057	Oil seal	1	
15	52WF5-023	Nut	2	
16	52WF1-044	Holding plate (1)	1	
17	52WF1-042	Rocking shaft	1	
18	52WF1-045	Holding plate (2)	1	
19	52WF1-046	Screw	2	
20	52WF1-056	Screw	1	
21	52WF1-055	Pin	1	
22	52WF1-054	Shaft bushing	1	
23	52WF1-027	Lower shaft	1	
24	22T3-002B1	Lower shaft collar	1	18306
25	1WF2-052	Screw	2	
26	22T3-007C2	Oil felt	2	
27	52WF1-029	Lower shaft bushing (rear)	1	
28	J0.0.5	Screw	2	
29	7KT1-007	Nut	1	
30	52WF1-026	Screw	1	
31	52WF1-023	Lower shaft crank	1	
32	52WF1-025	Crank pin	1	
33	52WF1-024	Sliding block	1	
34	52WF1-028	Lower shaft bushing (front)	1	
35	7KT5-055	Pin	1	
36	52WF1-040	Shuttle driving bracket	1	
37	52WF1-032	Shuttle ring	1	
38		Oscillating shuttle	1	KSP204-N
39	52WF1-033	Bibbin	1	
40	52WF1-031	Shuttle lace	1	
41	52WF1-036	Spring	2	
42	52WF1-037	Screw	2	
43	52WF1-038	Screw	2	
44	52WF1-039	Screw	2	
45	52WF1-035	Screw	2	
46	52WF1-034	Shuttle cover	1	

9. Threading components

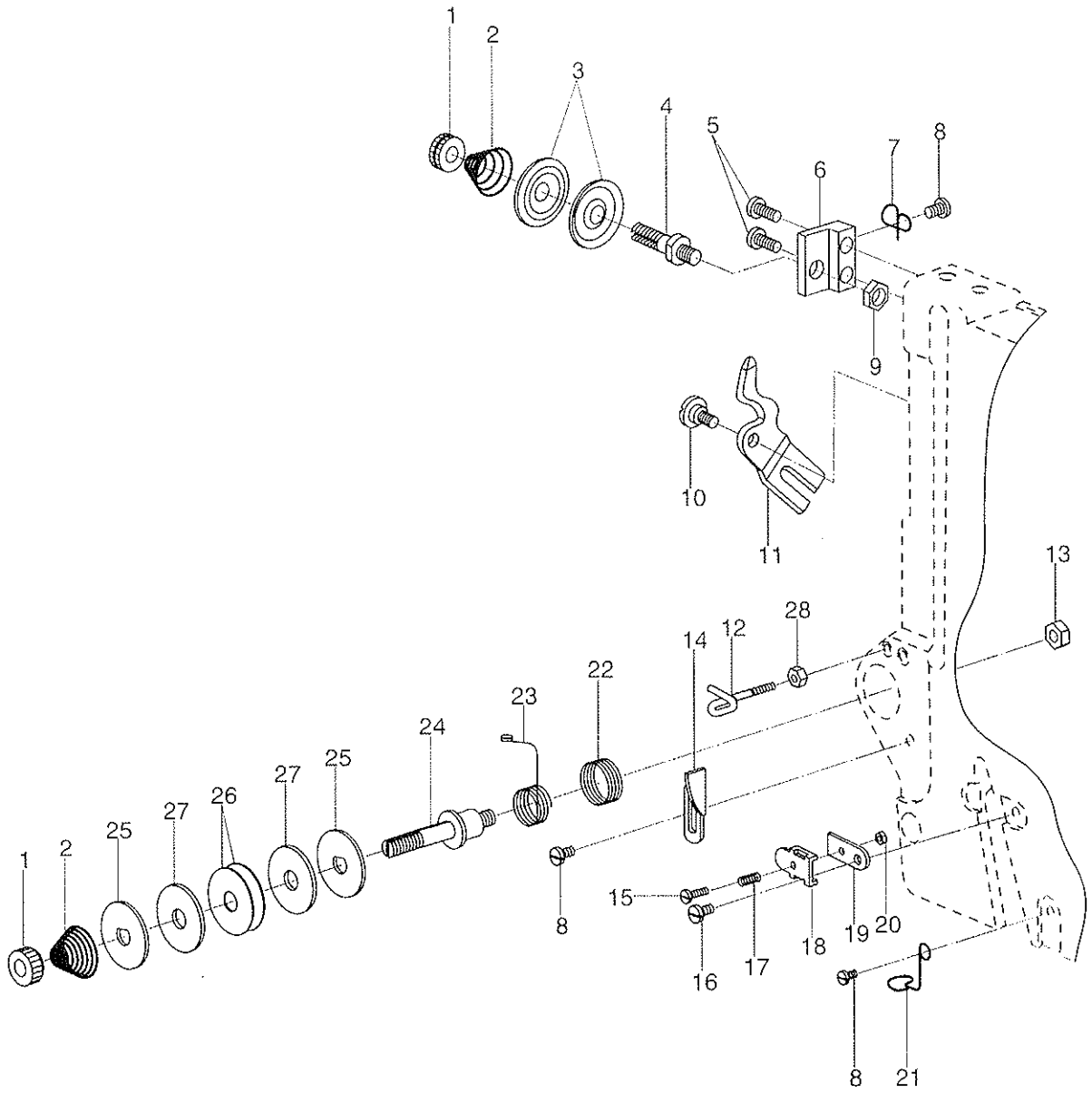

9. Threading components

NO	Parts No	Name of parts	Qty.	Remarks
1	6K4-022	Thread tension nut	1	
2	6K4-027	Thread tension spring	1	
3	22T1-012F5	Thread tension disc	2	18141
4	52WF2-010	Screw bar	1	
5	1WF5-039	Screw	2	
6	52WF2-011	Thread tension bracket	1	
7	52WF2-012	Upper thread guide	1	
8	16WF1-059	Screw	3	
9	7KT1-007	Nut	1	
10	52WF2-014	Screw	1	
11	52WF2-013	Thread tension releasing plate	1	
12	7KT2-003	Thread guide (middle)	1	
13	6K2-040	Nut	1	15/64" × 28
14	52WF2-016	Adjusting plate	1	
15	52WF2-058	Screw	1	
16	16WF2-015	Screw	1	1/8" × 44
17	52WF2-024	Spring	1	
18	52WF2-021	Thread guide plate	1	
19	52WF2-025	Installing plate	1	
20	52WF2-023	Nut	1	
21	52WF2-026	Lower thread guide	1	
22	6K4-015	Adjusting spring	1	
23	52WF2-015	Thread take-up spring	1	
24	52WF2-017	Screw bar	1	
25	52WF2-019	Wool felt	3	
26	52WF2-018	Assistant thread disc	1	
27	52WF2-020	Washer	2	
28	52WF2-053	Nut	1	

10. Bobbin thread winding components

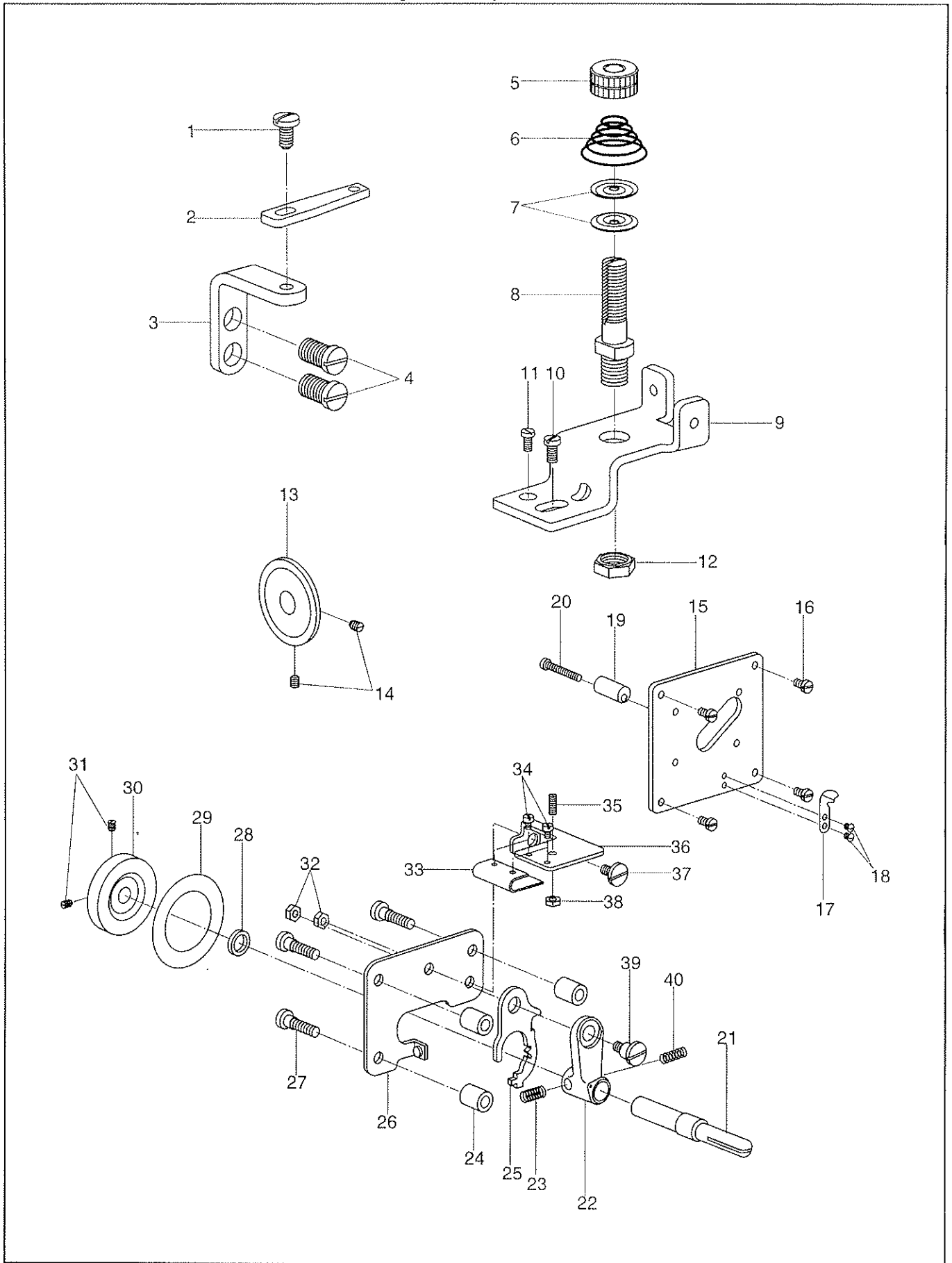

10. Bobbin thread winding components

NO	Parts No	Name of parts	Qty.	Remarks
1	13WF6-024	Screw	1	
2	52WF2-048	Thread guide plate	1	
3	52WF2-049	Bracket	1	
4	52WF3-027	Screw	2	
5	6K4-022	Nut	1	
6	52WF2-047	Thread tension spring	1	
7	22T1-012F5	Thread tension disc	2	18141
8	52WF2-010	Screw bar	1	
9	52WF2-046	Bracket	1	
10	22T2-019	Screw	1	171031
11	JO.O.50	Screw	1	
12	7KT1-007	Nut	1	
13	52WF2-045	Friction roller	1	
14	17T5-016	Screw	2	
15	52WF2-027	Supporting bracket	1	
16	21WF3-026	Screw	4	
17	52WF2-043	Bobbin thread cutter	1	
18	6A6-28	Screw	2	
19	52WF2-041	Bushing	1	
20	52WF2-042	Screw	1	
21	52WF2-029	Bobbin thread winding shaft	1	
22	52WF2-037	Winding crank	1	
23	52WF2-039	Spring (1)	1	
24	52WF2-031	Screw bushing	3	
25	52WF2-044	Locking plate	1	
26	52WF2-028	Thread winder plate	1	
27	52WF2-030	Screw	3	
28	52WF2-036	Washer	1	
29	13WF6-019	Rubber ring	1	
30	52WF2-035	Driving roller	1	
31		Screw	2	17076
32	52WF5-023	Nut	2	
33	52WF2-034	Thread winding stopper	1	
34	21WF2-012	Screw	2	
35	52WF2-033	Screw	1	
36	52WF2-032	Supporting bracket	1	
37	52WF2-057	Screw	1	
38	52WF2-023	Nut	1	
39	52WF5-038	Screw	1	
40	52WF2-040	Spring (2)	1	

11. Lifting components

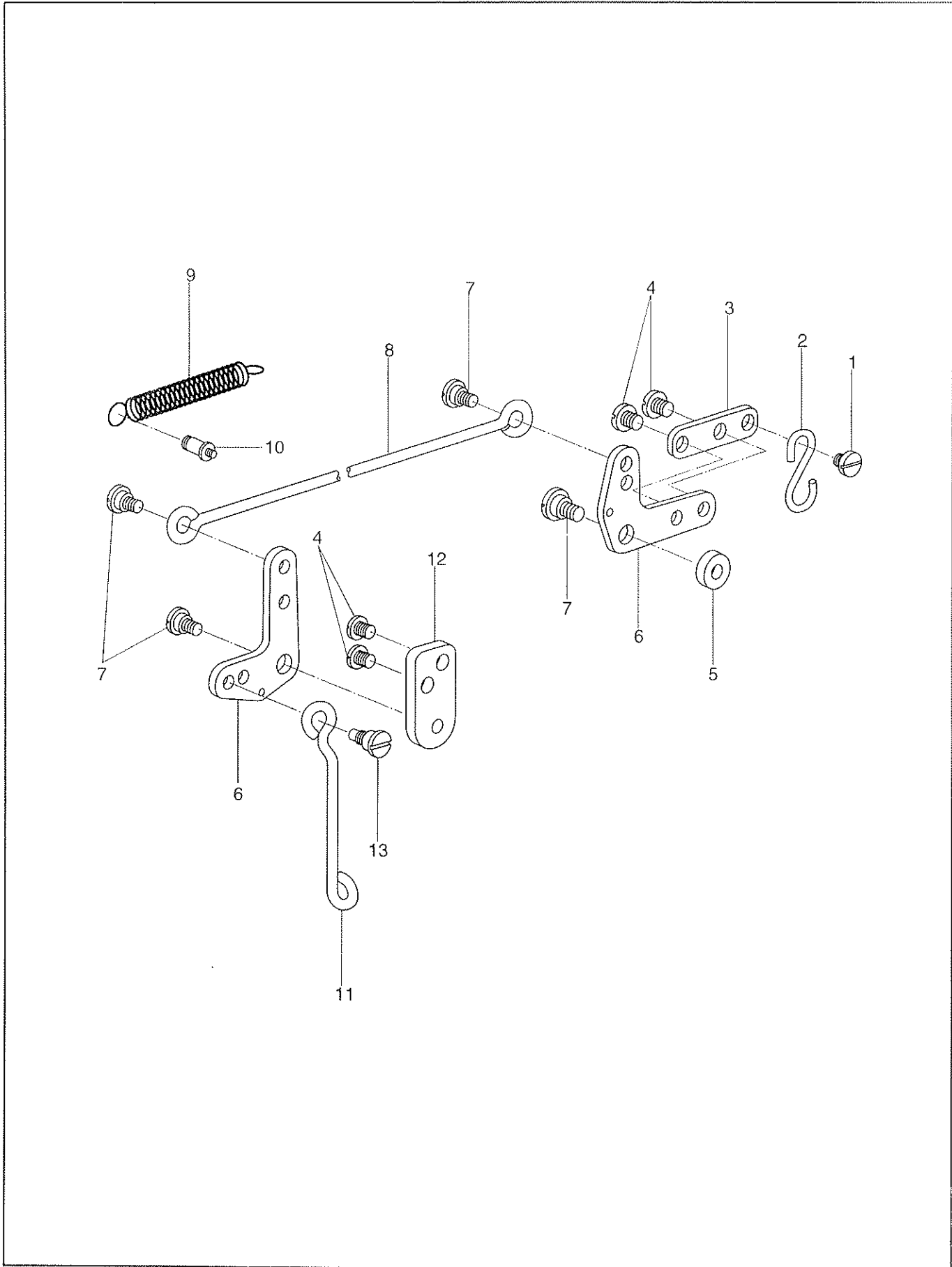

11. Lifting components

NO	Parts No	Name of parts	Qty.	Remarks
1	52WF3-030	Screw	1	
2	18WF1-016	"S" hook	1	
3	52WF3-026	Connecting plate	1	
4	52WF3-027	Screw	3	
5	52WF3-021	Washer	1	
6	52WF3-020	Lifting lever	2	
7	52WF3-025	Screw	4	
8	52WF3-024	Lifting rod	1	
9	52WF3-022	Reset spring	1	
10	52WF3-023	Screw	1	
11	52WF3-028	Lifting rod	1	
12	52WF3-029	Supporting plate	1	
13	52WF3-032	Screw	1	

12. Accessories

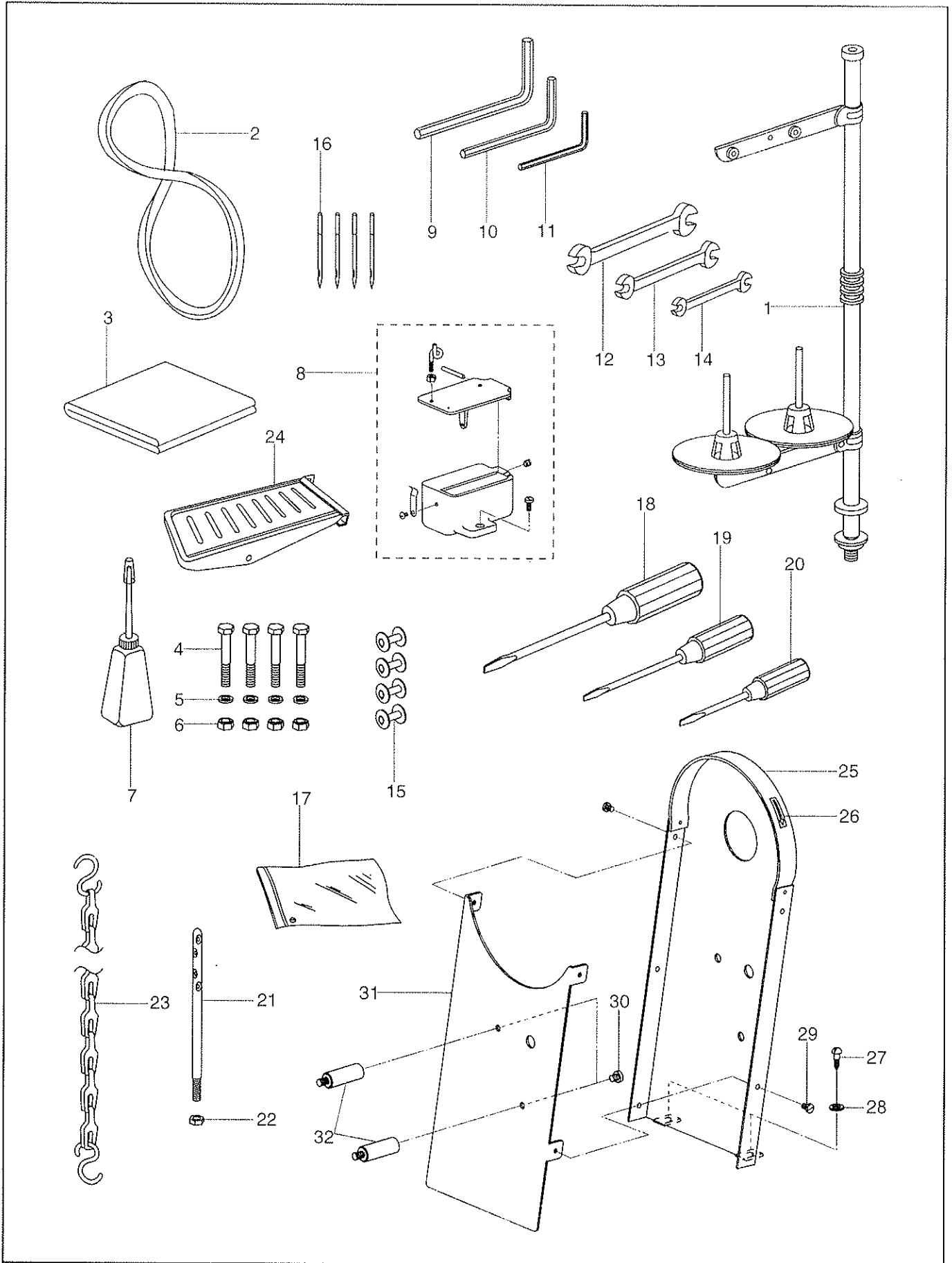

12. Accessories

NO	Parts No	Name of parts	Qty.	Remarks
1	4F-007	Thread stand assembly	1	
2		V-belt	1	M58
3	52WF6-001	Machine head cover	1	
4		Screw	4	GB5780-86
5		Washer	4	GB97.1-85-10
6		Nut	4	GB41-86-M10
7	33TF-010	Oil pot	1	
8		Silicon oil box assembly	1	
9		Hexagon wrench (big)	1	S=5MM
10		Hexagon wrench (middle)	1	S=4MM
11		Hexagon wrench (small)	1	S=3MM
12		Wrench (big)	1	12 × 14
13		Wrench (middle)	1	11 × 13
14		Wrench (small)	1	10 × 9
15	52WF1-033	Bobbin	4	
16		Needle	4	DY × 3 26"
17	33TF-010	Parts bag	1	
18	33TF-012	Screw driver (big)	1	
19	33TF-013	Screw driver (middle)	1	
20	33TF-014	Screw driver (small)	1	
21	52WF2-054	Thread guide pin	1	
22	52WF5-023	Nut	1	
23	18WF1-016	Chain	1	
24	18WF8-013	Pedal assembly	1	
25	52WF6-002	Safety cover A	1	
26	50WF5-012	Rotary direction	1	
27	33TF-017	Screw	2	
28	33TF-018	Washer	2	
29	33T3-006	Screw 1	6	
30	N3-7-27	Screw 2	2	
31	52WF6-003	Safety cover B	1	
32	52WF6-004	Screw	2	

- Please don't adjust and repair the machine by non-professionals, except adjusting stitch.
- Specifications subject to change without notice

TYPICAL SEWING MACHINE WANPING MACHINERY CO.,LTD.

Add: Wanping Town, Wujiang City, Jiangsu Province, China.

Tel: +86-512-63391278

Fax: +86-512-63391371

Post Code: 215223

Http: //www.typicalwpchina.com

E-mail: bzf@public1.sz.js.cn

TW3-441

**EXTRA HEAVY-DUTY COMPOUND FEED
CYLINDER ARM LOCKSTITCH SEWING MACHINE**



This machine may only be operated by adequately trained operators only after having completely read and understood the instruction manual.

Parts are subject to changes in design without prior notice.



Certificate of the international ISO9001



Certificate of the ISO14001



Certificate of the international CE



Certificate for Ecolabeling Product



Certificate for Energy Conservation Product

XI'AN TYPICAL EUROPE GmbH

Hertelsbrunnenring 9

D-67657 Kaiserslautern

Tel.: +49 (0)631 316019-0

Fax: +49 (0)631 316019-11

E-mail: sales@typical-europe.com
www.typical-europe.com